

**RIDGID 15 in. (381 mm)  
DRILL PRESS  
MODEL NO. DP15501  
REPAIR SHEET**

RIDGID 15 in. (381 mm) DRILL PRESS - MODEL NUMBER DP15501

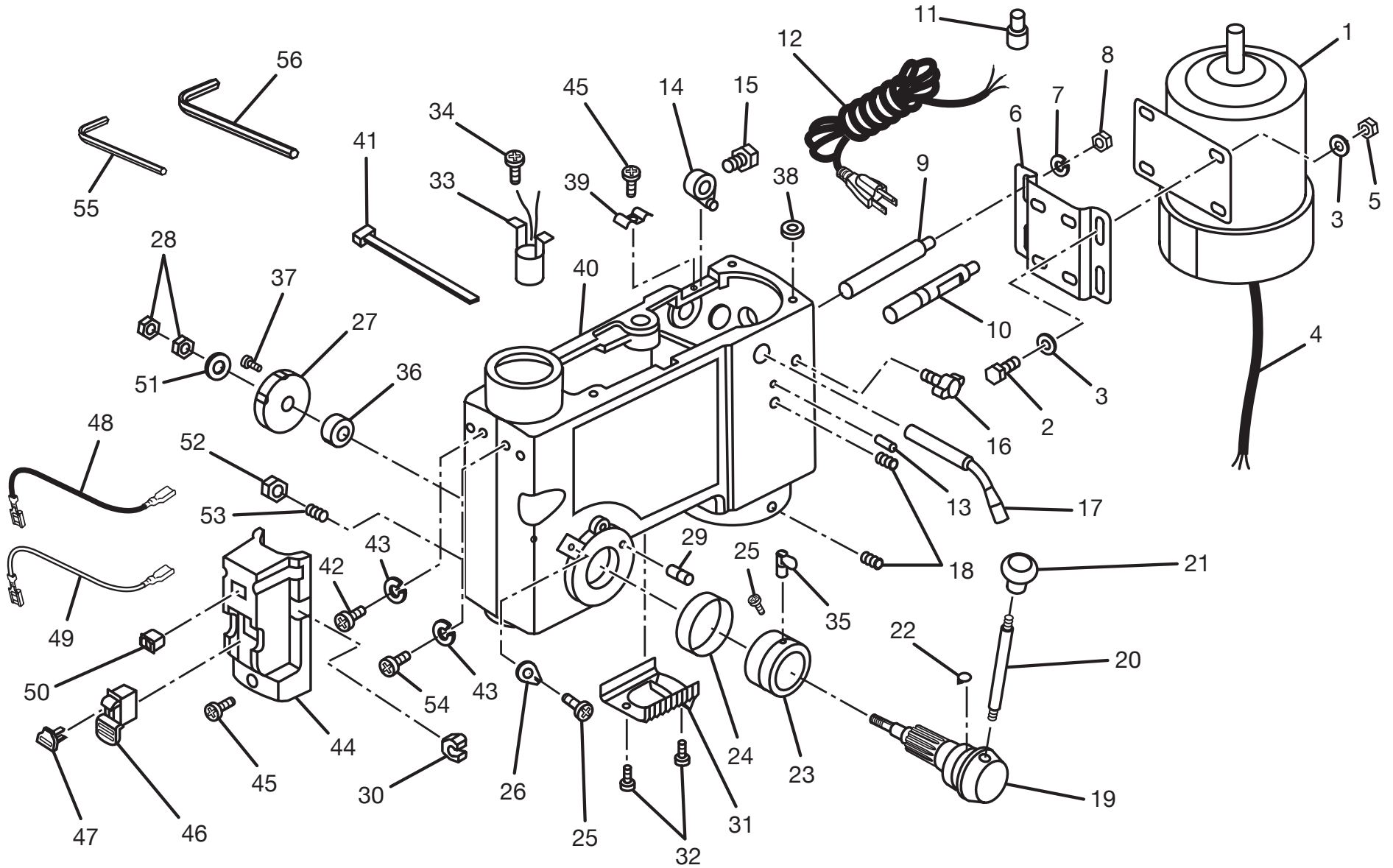

## RIDGID 15 in. (381 mm) DRILL PRESS – MODEL NUMBER DP15501

The model number will be found on a plate attached to the motor housing. Always mention the model number in all correspondence regarding your **DRILL PRESS** or when ordering repair parts.

### PARTS LIST

KEY NO.	PART NUMBER	DESCRIPTION	QTY.	KEY NO.	PART NUMBER	DESCRIPTION	QTY.
1	828929	MOTOR.....	1	29	828917	PIN STOP.....	1
2	820381-2	* SCREW, HEX HD (M8 X 1.25-20).....	4	30	828877	CHUCK KEY HOLDER.....	1
3	821063-2	* WASHER (M8 X 16 X 1.2) .....	8	31	828963	LENS ASSEMBLY .....	1
4	828940	MOTOR CORD.....	1	32	820240-6	* SCREW, PAN HD. (M5 X 0.8-12).....	2
5	824026-7	* NUT, HEX M8 X 1.25.....	4	33	829595	BULB SOCKET ASSEMBLY .....	1
6	817336-1	MOTOR MOUNT.....	1	34	820244	* SCREW, PAN HD. (M6 X 1.0 - 12).....	2
7	820383-8	* LOCK WASHER 12 mm .....	2	35	817343	DEPTH LOCK SCREW.....	1
8	820236-9	* NUT, HEX (M12 X 1.75).....	2	36	828928	PINION BEARING SHAFT .....	1
9	817495	SUPPORT MOTOR BRACKET.....	1	37	820378	* SCREW, SOC. CAP (M4 X 0.7 - 10) .....	1
10	817516	SUPPORT MOTOR BRACKET.....	1	38	820294	FOAM WASHER.....	4
11	817330	WIRE CONNECTOR .....	2	39	829689	CORD CLAMP .....	1
12	828941	POWER CORD W/PLUG .....	1	40	829826	HEAD ASSEMBLY .....	1
13	821733-181	SPRING PIN (6 X 26).....	2	41	810506-3	TIE WIRE .....	2
14	817317	ADJUSTING LEVER.....	1	42	829803	* SCREW, HEX HD.. (M5 X 0.8) .....	1
15	820381-4	* SCREW, HEX HD (M8 X 1.25-16).....	1	43	820241-4	LOCKWASHER, M5.....	2
16	817320	MOTOR ADJUSTING KNOB.....	2	44	828921	BOX SWITCH ASSEMBLY .....	1
17	817494	BELT TENSION HANDLE.....	1	45	820240	* SCREW, PAN HD. (M5 X 0.8 -16).....	3
18	821750	* SCREW, HEX SS (M10 X 1.50-12).....	2	46	829787	LOCKING SWITCH .....	1
19	828904	HUB ASSEMBLY.....	1	47	826122	SWITCH KEY .....	1
20	826445	ROD .....	3	48	829597	LEAD, BLACK .....	1
21	826441	KNOB.....	3	49	829597-1	LEAD, WHITE .....	1
22	817300	SCALE GUIDE.....	1	50	828923	ROCKER SWITCH .....	1
23	829590	DEPTH STOP RING .....	1	51	829690	WASHER, (12 mm) .....	1
24	828876	DEPTH SCALE.....	1	52	820236-8	* NUT, HEX (M10 X 1.5).....	1
25	816743-4	* SCREW, PAN CR. (M4 X 0.7).....	2	53	817308	SCREW SI. SET FI. PT. .....	1
26	826057	POINTER.....	1	54	820240-3	* SCREW, PAN HD (M5 X 0.8-6).....	1
27	828880	SPRING ASSEMBLY .....	1	55	813317-6	WRENCH, (3 mm) HEX KEY .....	1
28	821738-3	* SCREW, HEX (M12 X 1.5-8).....	2	56	813317-8	WRENCH, (5 mm) HEX KEY .....	1
					983000-391	OPERATOR'S MANUAL.....	1
					10-06-04	(REV:00)	

\* STANDARD HARDWARE ITEM – MAY BE PURCHASED LOCALLY

RIDGID 15 in. (381 mm) DRILL PRESS – MODEL NUMBER DP15501

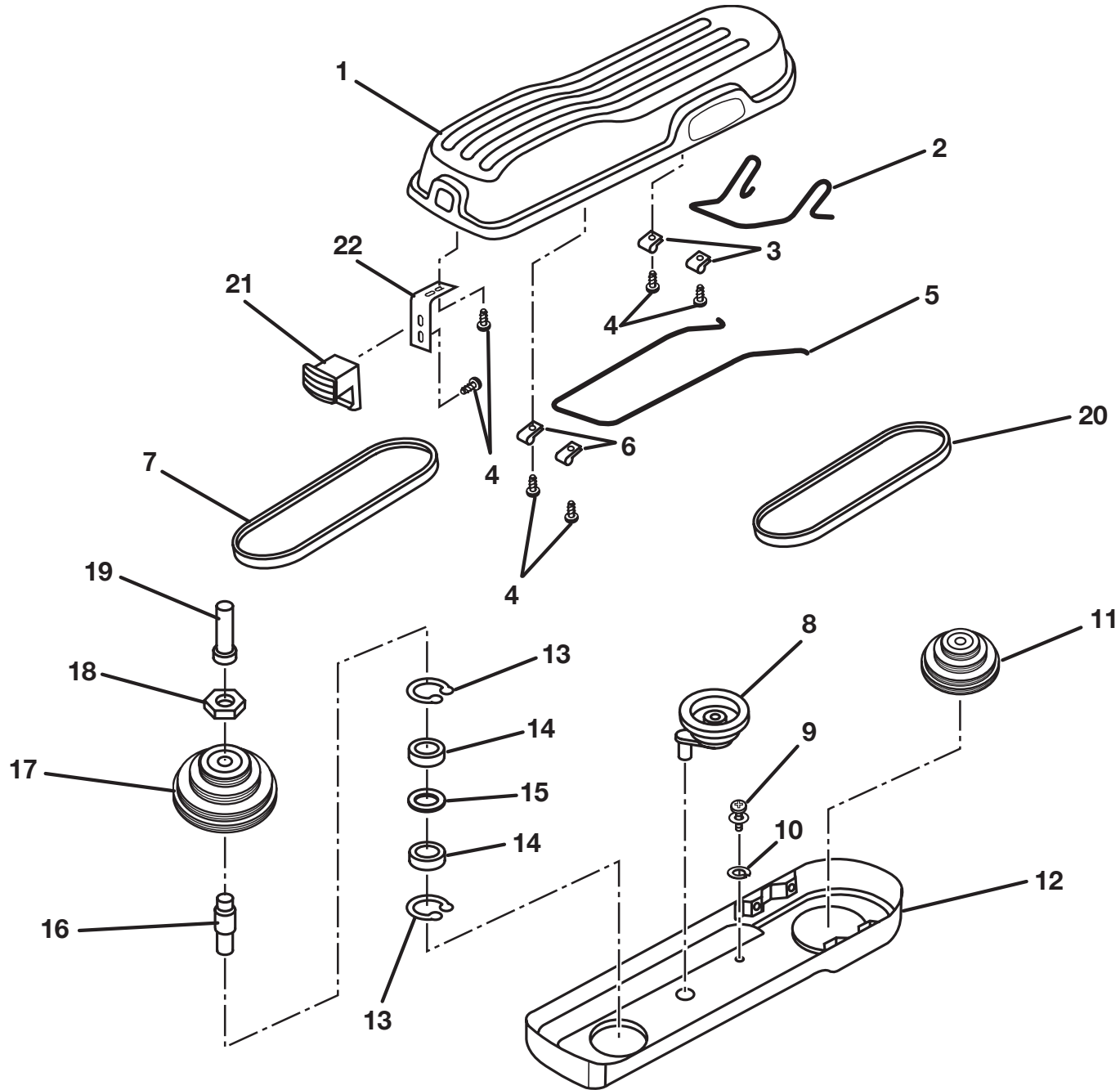

## PARTS LIST

KEY NO.	PART NUMBER	DESCRIPTION	QTY.
1	829775	UPPER GUARD.....	1
2	828814	LINK, REAR.....	1
3	828812	CLAMP.....	2
4	828932	* SCREW, PAN HD (M5.5 X 1.8-12).....	8
5	828813	LINK, FRONT .....	1
6	828811	CLAMP.....	2
7	816439-4	BELT, (27 in.) .....	1
8	828919	IDLER PULLEY ASSEMBLY.....	1
9	817358-1	* SCREW, RD. HD (M6 X 1.0).....	4
10	820241-5	* LOCK WASHER (M6) .....	4
11	828818	MOTOR PULLEY ASSMBLY.....	1
12	828816	LOWER GUARD.....	1
13	817537	RETAINING RING.....	2
14	817530	BALL BEARING (20 mm).....	2
15	817536	SPACER.....	1
16	821734	PULLEY INSERT .....	1
17	828849	SPINDLE PULLEY.....	1
18	821742	PULLEY NUT (M24 X 1.5 L.H.).....	1
19	829688	SPINDLE CAP.....	1
20	816439-5	BELT (25 in.).....	1
21	828820	LATCH.....	1
22	828821	LATCH SPRING .....	1
23	828936	WARNING LABEL (NOT SHOWN) .....	1
24	828962	RIDGID PLATE LABEL (NOT SHOWN).....	1
25	828964	LAMP LABEL (NOT SHOWN) .....	1
26	826434-1	MODEL, NAME PLATE LABEL (NOT SHOWN).....	1
27	828930	DATA PLATE LABEL (NOTSHOWN).....	1
28	830165	ROTATE SPEED DATA LABEL (NOT SHOWN).....	1
29	826463-4	RIDGID LABEL.....	2

\* STANDARD HARDWARE ITEM – MAY BE PURCHASED LOCALLY

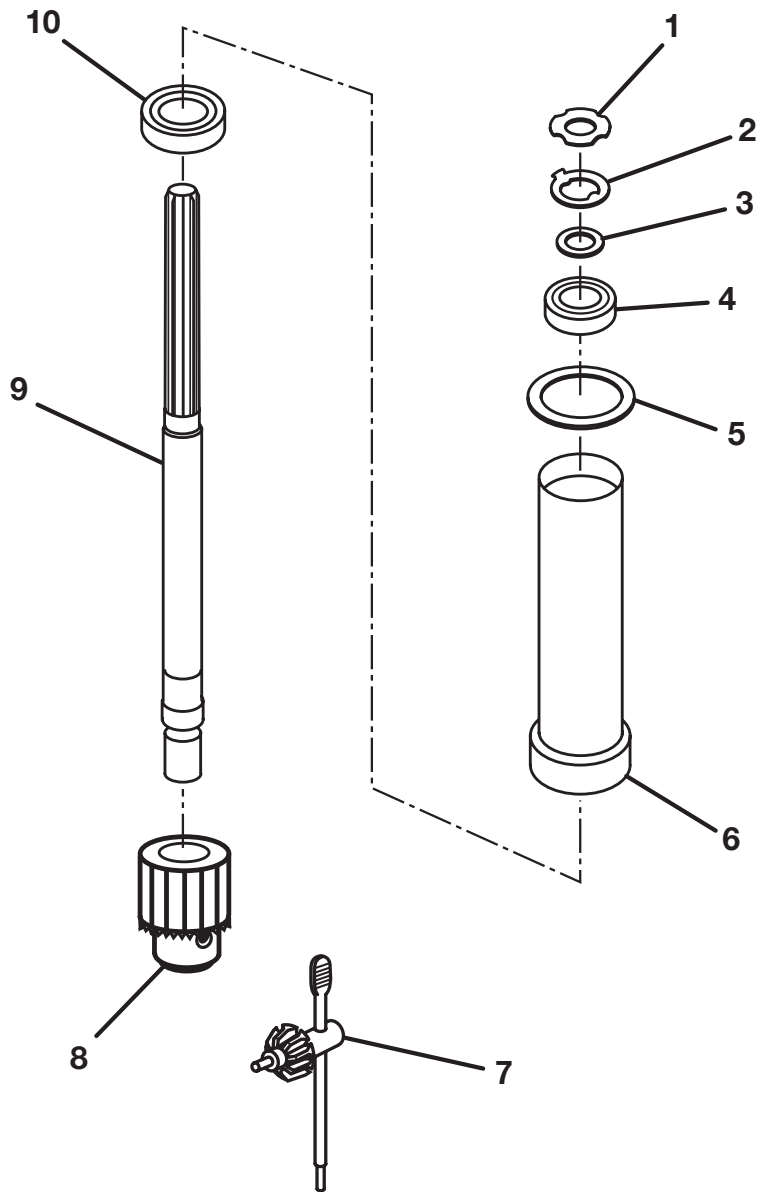

## PARTS LIST

KEY NO.	PART NUMBER	DESCRIPTION	QTY.
1	817309	* LOCK NUT (M7 X 1.0) .....	1
2	817310	LOCK RING.....	1
3	817311	WASHER.....	1
4	813480	BALL BEARING (17 mm).....	1
5	817535	QUILL GASKET.....	1
6	828875	QUILL TUBE.....	1
7	817339	CHUCK KEY .....	1
8	817340	CHUCK .....	1
9	828908	SPINDLE .....	1
10	817529	BALL BEARING.....	1

\* STANDARD HARDWARE ITEM – MAY BE PURCHASED LOCALLY

RIDGID 15 in. (381 mm) DRILL PRESS - MODEL NUMBER DP15501

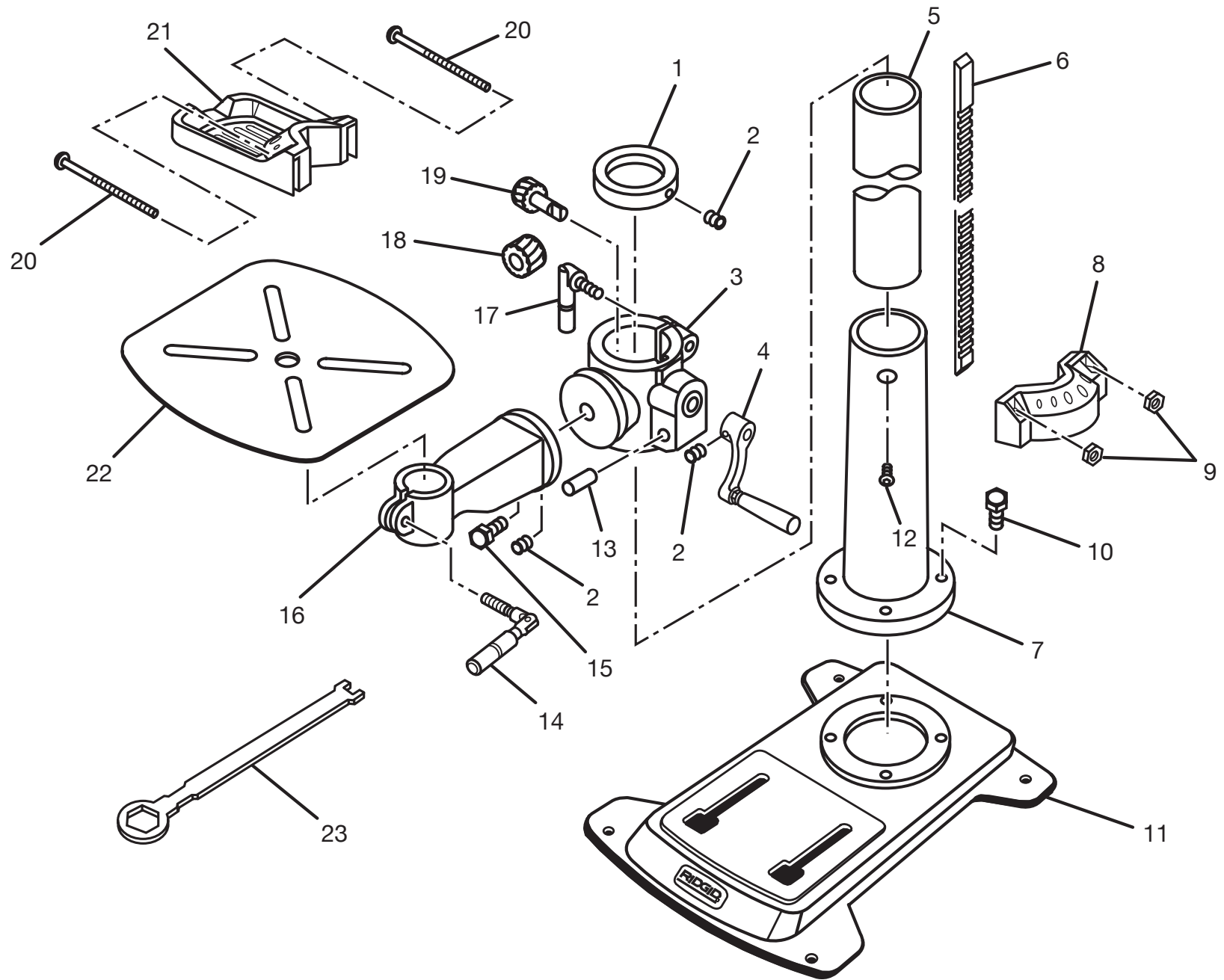

## PARTS LIST

KEY NO.	PART NUMBER	DESCRIPTION	QTY.
1	817478	RACK COLLAR .....	1
2	820245	* SCREW, HEX SOC. SET (M6 X 1.0-10).....	3
3	821861-2	SUPPORT TABLE W/INDICATOR .....	1
4	826439	CRANK, W/SET SCREW.....	1
5	821880	COLUMN TUBE .....	1
6	828927	RACK .....	1
7	821881-1	SUPPORT COLUMN.....	1
8	828870	TRAY, REAR .....	1
9	813164-6	NUT, HEX (M5) .....	2
10	821754	* SCREW, HEX HD. (M10 X 1.5-12).....	4
11	828961	BASE.....	1
12	821750	* SCREW, HEX SOC. SET (M10 X 1.5-12).....	1
13	817288	GEAR PIN.....	1
14	817290-3	TABLE CLAMP .....	1
15	821732	* SCREW, HEX HD. (M16 X 2.0-35).....	1
16	817777-3	TABLE ARM, W/SCALE .....	1
17	817294-2	COLUMN CLAMP .....	1
18	817350	HELICAL GEAR.....	1
19	817349	ELEVATION WORM.....	1
20	10251002	* SCREW, PAN HD. (M5 X 0.8-60).....	2
21	828871	TRAY, FRONT .....	1
22	828903	TABLE .....	1
23	826438	HEX WRENCH, (24 mm) .....	1

\* STANDARD HARDWARE ITEM – MAY BE PURCHASED LOCALLY

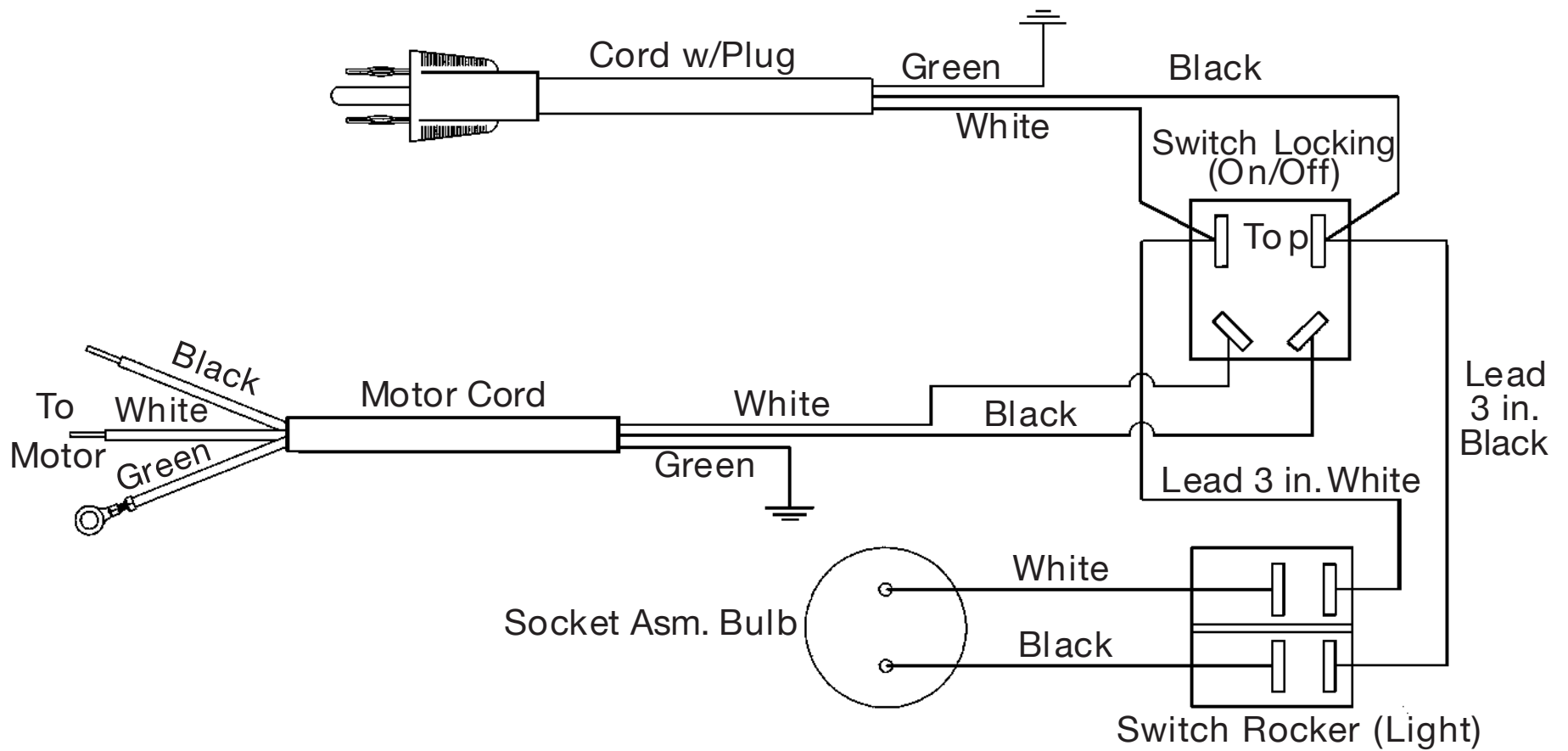

**WIRING DIAGRAM**