

RIDGID®

OPERATOR'S MANUAL

1/2 in. HAMMER/PULSE DRILL
DOUBLE INSULATED
R5010

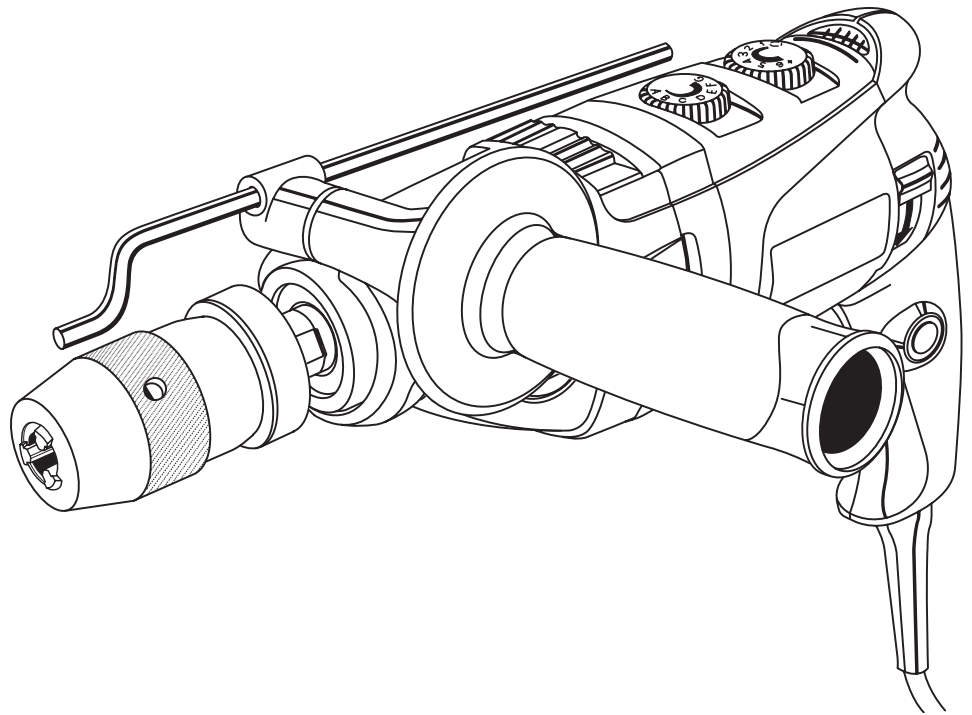

Your hammer drill has been engineered and manufactured to our high standards for dependability, ease of operation, and operator safety. When properly cared for, it will give you years of rugged, trouble-free performance.

⚠ WARNING:

To reduce the risk of injury, the user must read and understand the operator's manual before using this product.

Thank you for buying a RIDGID product.

SAVE THIS MANUAL FOR FUTURE REFERENCE

TABLE OF CONTENTS

■ Introduction	2
■ General Safety Rules.....	3-4
■ Specific Safety Rules.....	4
■ Symbols.....	5-6
■ Electrical	7
■ Features.....	8
■ Unpacking	9
■ Assembly.....	9-10
■ Operation.....	11-13
■ Adjustments	14
■ Maintenance.....	15-16
■ Warranty	17
■ Customer Service Information.....	18

INTRODUCTION

This tool has many features for making its use more pleasant and enjoyable. Safety, performance, and dependability have been given top priority in the design of this product making it easy to maintain and operate.

GENERAL SAFETY RULES

⚠ WARNING:

Read and understand all instructions. Failure to follow all instructions listed below, may result in electric shock, fire and/or serious personal injury.

SAVE THESE INSTRUCTIONS

WORK AREA

- **Keep your work area clean and well lit.** Cluttered benches and dark areas invite accidents.
- **Do not operate power tools in explosive atmospheres, such as in the presence of flammable liquids, gases, or dust.** Power tools create sparks which may ignite the dust or fumes.
- **Keep bystanders, children, and visitors away while operating a power tool.** Distractions can cause you to lose control.

ELECTRICAL SAFETY

- **Double insulated tools are equipped with a polarized plug (one blade is wider than the other). This plug will fit in a polarized outlet only one way. If the plug does not fit fully in the outlet, reverse the plug. If it still does not fit, contact a qualified electrician to install a polarized outlet. Do not change the plug in any way.** Double insulation  eliminates the need for the three-wire grounded power cord and grounded power supply system.
- **Avoid body contact with grounded surfaces such as pipes, radiators, ranges, and refrigerators.** There is an increased risk of electric shock if your body is grounded.
- **Don't expose power tools to rain or wet conditions.** Water entering a power tool will increase the risk of electric shock.
- **Do not abuse the cord. Never use the cord to carry the tools or pull the plug from an outlet. Keep cord away from heat, oil, sharp edges, or moving parts. Replace damaged cords immediately.** Damaged cords increase the risk of electric shock.
- **When operating a power tool outside, use an outdoor extension cord marked "W-A" or "W".** These cords are rated for outdoor use and reduce the risk of electric shock.

PERSONAL SAFETY

- **Stay alert, watch what you are doing and use common sense when operating a power tool. Do not use tool while tired or under the influence of drugs, alcohol, or medication.** A moment of inattention while operating power tools may result in serious personal injury.
- **Dress properly. Do not wear loose clothing or jewelry. Contain long hair. Keep your hair, clothing, and gloves away from moving parts.** Loose clothes, jewelry, or long hair can be caught in moving parts.

- **Avoid accidental starting. Be sure switch is off before plugging in.** Carrying tools with your finger on the switch or plugging in tools that have the switch on invites accidents.
- **Remove adjusting keys or wrenches before turning the tool on.** A wrench or a key that is left attached to a rotating part of the tool may result in personal injury.
- **Do not overreach. Keep proper footing and balance at all times.** Proper footing and balance enables better control of the tool in unexpected situations.
- **Use safety equipment. Always wear eye protection.** Dust mask, nonskid safety shoes, hard hat, or hearing protection must be used for appropriate conditions.
- **Do not wear loose clothing or jewelry. Contain long hair.** Loose clothes, jewelry, or long hair can be drawn into air vents.
- **Do not use on a ladder or unstable support.** Stable footing on a solid surface enables better control of the tool in unexpected situations.

TOOL USE AND CARE

- **Use clamps or other practical way to secure and support the workpiece to a stable platform.** Holding the work by hand or against your body is unstable and may lead to loss of control.
- **Do not force tool. Use the correct tool for your application.** The correct tool will do the job better and safer at the rate for which it is designed.
- **Do not use tool if switch does not turn it on or off.** Any tool that cannot be controlled with the switch is dangerous and must be repaired.
- **Disconnect the plug from power source before making any adjustments, changing accessories, or storing the tool.** Such preventive safety measures reduce the risk of starting the tool accidentally.
- **Store idle tools out of the reach of children and other untrained persons.** Tools are dangerous in the hands of untrained users.
- **Maintain tools with care. Keep cutting tools sharp and clean.** Properly maintained tools with sharp cutting edges are less likely to bind and are easier to control.
- **Check for misalignment or binding of moving parts, breakage of parts, and any other condition that may affect the tool's operation. If damaged, have the tool serviced before using.** Many accidents are caused by poorly maintained tools.
- **Use only accessories that are recommended by the manufacturer for your model.** Accessories that may be suitable for one tool, may become hazardous when used on another tool.
- **Keep the tool and its handle dry, clean and free from oil and grease.** Always use a clean cloth when cleaning. Never use brake fluids, gasoline, petroleum-based products, or any strong solvents to clean your tool. Following this rule will reduce the risk of loss of control and deterioration of the enclosure plastic.

GENERAL SAFETY RULES

SERVICE

- **Tool service must be performed only by qualified repair personnel.** Service or maintenance performed by unqualified personnel may result in a risk of injury.

SPECIFIC SAFETY RULES

- **Hold tool by insulated gripping surfaces when performing an operation where the cutting tool may contact hidden wiring or its own cord.** Contact with a “live” wire will make exposed metal parts of the cutting tool “live” and shock the operator.

ADDITIONAL SAFETY RULES

- **Know your power tool. Read operator’s manual carefully. Learn its applications and limitations, as well as the specific potential hazards related to this tool.** Following this rule will reduce the risk of electric shock, fire, or serious injury.
- **Always wear safety glasses. Everyday eyeglasses have only impact-resistant lenses; they are NOT safety glasses.** Following this rule will reduce the risk of serious personal injury.
- **Protect your lungs. Wear a face or dust mask if the operation is dusty.** Following this rule will reduce the risk of serious personal injury.
- **Protect your hearing. Wear hearing protection during extended periods of operation.** Following this rule will reduce the risk of serious personal injury.
- **Inspect tool cords periodically and, if damaged, have repaired at your nearest Authorized Service Center. Constantly stay aware of cord location.** Following this rule will reduce the risk of electric shock or fire.
- **Check damaged parts. Before further use of the tool, a guard or other part that is damaged should be carefully checked to determine that it will operate properly and perform its intended function. Check for alignment of moving parts, binding of moving parts,**

- **When servicing a tool, use only identical replacement parts. Follow instructions in the Maintenance section of this manual.** Use of unauthorized parts or failure to follow Maintenance Instructions may create a risk of shock or injury.

breakage of parts, mounting, and any other conditions that may affect its operation. A guard or other part that is damaged should be properly repaired or replaced by an authorized service center. Following this rule will reduce the risk of shock, fire, or serious injury.

- **Do not abuse cord. Never carry the tool by the cord or yank it to disconnect it from the receptacle. Keep cord away from heat, oil, and sharp edges.** Following this rule will reduce the risk of electric shock or fire.
- **Make sure your extension cord is in good condition. When using an extension cord, be sure to use one heavy enough to carry the current your product will draw. A wire gage size (A.W.G.) of at least 14 is recommended for an extension cord 50 feet or less in length. A cord exceeding 100 feet is not recommended. If in doubt, use the next heavier gage. The smaller the gage number, the heavier the cord.** An undersized cord will cause a drop in line voltage resulting in loss of power and overheating.
- **Inspect for and remove all nails from lumber before using this tool.** Following this rule will reduce the risk of serious personal injury.
- **Drugs, alcohol, medication. Do not operate tool while under the influence of drugs, alcohol, or any medication.** Following this rule will reduce the risk of electric shock, fire, or serious personal injury.
- **Save these instructions.** Refer to them frequently and use them to instruct others who may use this tool. If you loan someone this tool, loan them these instructions also.

WARNING:









Some dust created by power sanding, sawing, grinding, drilling, and other construction activities contains chemicals known to cause cancer, birth defects or other reproductive harm. Some examples of these chemicals are:

- lead from lead-based paints,
- crystalline silica from bricks and cement and other masonry products, and
- arsenic and chromium from chemically-treated lumber.

Your risk from these exposures varies, depending on how often you do this type of work. To reduce your exposure to these chemicals: work in a well ventilated area, and work with approved safety equipment, such as those dust masks that are specially designed to filter out microscopic particles.



SYMBOLS

Some of the following symbols may be used on this tool. Please study them and learn their meaning. Proper interpretation of these symbols will allow you to operate the tool better and safer.

SYMBOL	NAME	DESIGNATION/EXPLANATION
V	Volts	Voltage
A	Amperes	Current
Hz	Hertz	Frequency (cycles per second)
W	Watt	Power
min	Minutes	Time
~	Alternating Current	Type of current
≡	Direct Current	Type or a characteristic of current
n_0	No Load Speed	Rotational speed, at no load
	Class II Construction	Double-insulated construction
.../min	Per Minute	Revolutions, strokes, surface speed, orbits etc., per minute
	Wet Conditions Alert	Do not expose to rain or use in damp locations.
	Read The Operator's Manual	To reduce the risk of injury, user must read and understand operator's manual before using this product.
	Eye Protection	Always wear safety goggles or safety glasses with side shields and a full face shield when operating this product.
	Safety Alert	Precautions that involve your safety.
	No Hands Symbol	Failure to keep your hands away from the blade will result in serious personal injury.
	No Hands Symbol	Failure to keep your hands away from the blade will result in serious personal injury.
	No Hands Symbol	Failure to keep your hands away from the blade will result in serious personal injury.
	No Hands Symbol	Failure to keep your hands away from the blade will result in serious personal injury.

SYMBOLS

The following signal words and meanings are intended to explain the levels of risk associated with this product.

SYMBOL	SIGNAL	MEANING
	DANGER:	Indicates an imminently hazardous situation, which, if not avoided, will result in death or serious injury.
	WARNING:	Indicates a potentially hazardous situation, which, if not avoided, could result in Death or serious injury.
	CAUTION:	Indicates a potentially hazardous situation, which, if not avoided, may result in minor or moderate injury.
	CAUTION:	(Without Safety Alert Symbol) Indicates a situation that may result in property damage.

SERVICE

Servicing requires extreme care and knowledge and should be performed only by a qualified service technician. For service we suggest you return the product to your nearest **AUTHORIZED SERVICE CENTER** for repair. When servicing, use only identical replacement parts.

WARNING:

To avoid serious personal injury, do not attempt to use this product until you read thoroughly and understand completely the operator's manual. Save this operator's manual and review frequently for continuing safe operation and instructing others who may use this product.

WARNING:



The operation of any power tool can result in foreign objects being thrown into your eyes, which can result in severe eye damage. Before beginning power tool operation, always wear safety goggles or safety glasses with side shields and a full face shield when needed. We recommend Wide Vision Safety Mask for use over eyeglasses or standard safety glasses with side shields. Always use eye protection which is marked to comply with ANSI Z87.1.

SAVE THESE INSTRUCTIONS

ELECTRICAL

DOUBLE INSULATION

Double insulation is a concept in safety in electric power tools, which eliminates the need for the usual three-wire grounded power cord. All exposed metal parts are isolated from the internal metal motor components with protecting insulation. Double insulated tools do not need to be grounded.

WARNING:

The double insulated system is intended to protect the user from shock resulting from a break in the tool's internal wiring. Observe all normal safety precautions to avoid electrical shock.

Servicing of a tool with double insulation requires extreme care and knowledge of the system and should be performed only by a qualified service technician. For service, we suggest you return the tool to your nearest authorized service center for repair. Always use original factory replacement parts when servicing.

ELECTRICAL CONNECTION

This tool has a precision-built electric motor. **It should be connected to a power supply that is 120 volts, 60 Hz, AC only (normal household current).** Do not operate this tool on direct current (DC). A substantial voltage drop will cause a loss of power and the motor will overheat. If your tool does not operate when plugged into an outlet, double-check the power supply.

EXTENSION CORDS

When using a power tool at a considerable distance from a power source, be sure to use an extension cord that has the capacity to handle the current the tool will draw. An undersized cord will cause a drop in line voltage, resulting in overheating and loss of power. Use the chart to determine the minimum wire size required in an extension cord. Only round jacketed cords listed by Underwriter's Laboratories (UL) should be used.

When working outdoors with a tool, use an extension cord that is designed for outside use. This type of cord is designated with "WA" on the cord's jacket.

Before using any extension cord, inspect it for loose or exposed wires and cut or worn insulation.

**Ampere rating (on tool faceplate)

Cord Length	Wire Size (A.W.G.)					
	0-2.0	2.1-3.4	3.5-5.0	5.1-7.0	7.1-12.0	12.1-16.0
25'	16	16	16	16	14	14
50'	16	16	16	14	14	12
100'	16	16	14	12	10	—

**Used on 12 gauge - 20 amp circuit.

WARNING:

Keep the extension cord clear of the working area. Position the cord so that it will not get caught on lumber, tools or other obstructions while you are working with a power tool. Failure to do so can result in serious personal injury.

WARNING:

Check extension cords before each use. If damaged replace immediately. Never use tool with a damaged cord since touching the damaged area could cause electrical shock resulting in serious injury.

FEATURES

SPECIFICATIONS

Chuck Capacity	1/2 in. (13 mm)
Input	120 V, 60 Hz, AC only, 9.0 Amps
Switch.....	Variable Speed
Hammer Speed	0-57,000 BPM
No Load Speed	Low (0-1,000/min) & High (0-3,000/min)

Before using this tool, familiarize yourself with all operating features and safety requirements. However, do not let familiarity with the tool make you careless.

This new drill is equipped with the following features. See *Figure 1*.

SWITCH

This hammer drill has a conveniently located switch trigger.

DEPTH GAUGE ROD

A depth gauge rod is installed on the auxiliary handle assembly to assist you in controlling the depth of drilled holes.

AUXILIARY HANDLE ASSEMBLY

An auxiliary handle is installed on the hammer drill. For ease of operation, you may use the handle with either the left hand or the right hand.

REVERSIBLE

This hammer drill allows you to reverse the bit rotation. You can control the direction with the switch located on the side of the tool.

PULSE MODE DRILLING

Allows for working with damaged screw heads, countersinking screws in wood, unscrewing very tight screws, and starting a drill bit on hard, smooth surfaces.

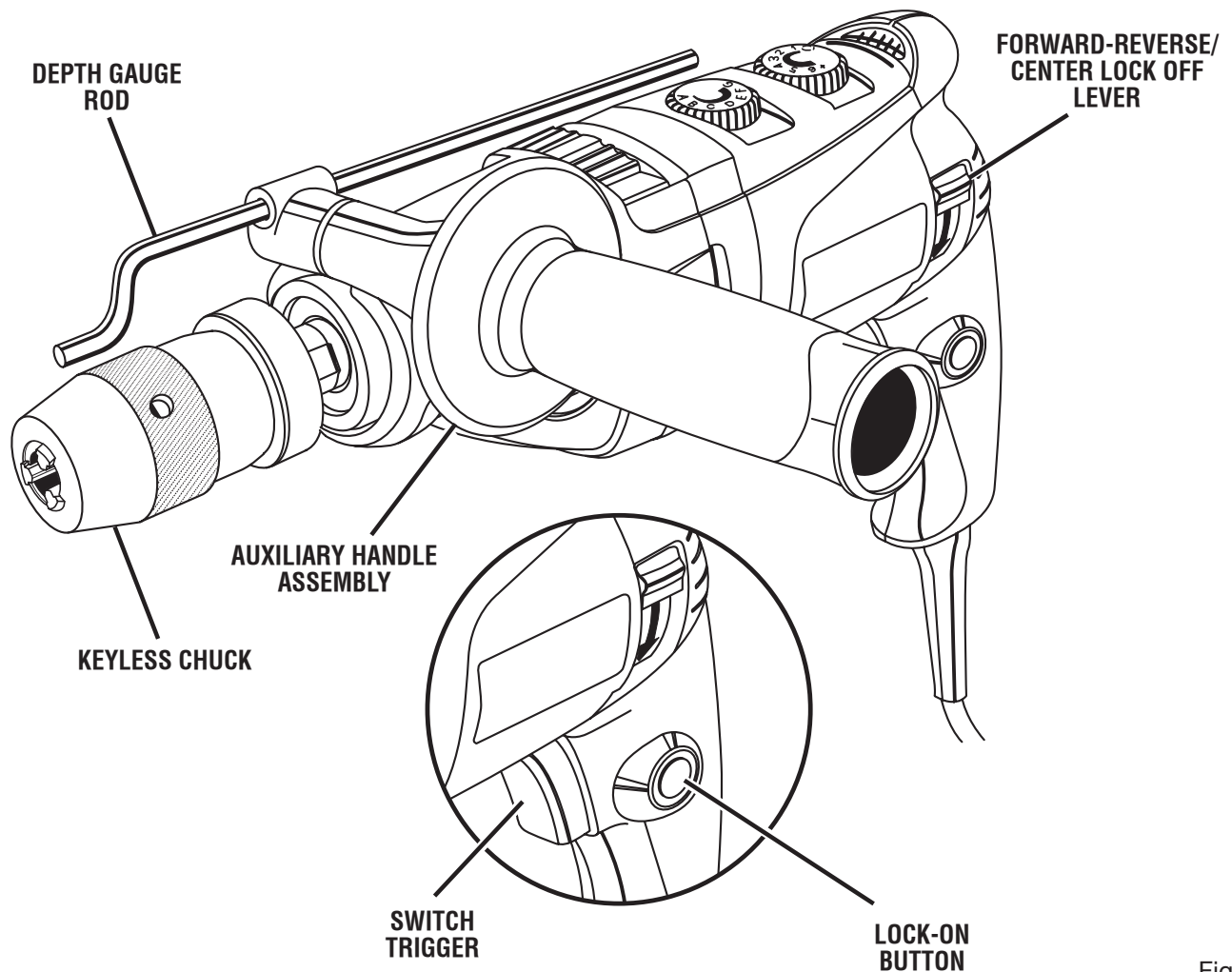

Fig. 1

UNPACKING

INSTRUCTIONS

The drill has been shipped completely assembled.

- Carefully remove the tool from the box.
- Make sure that all items listed in the packing list are included.
- Inspect the tool carefully to make sure no breakage or damage occurred during shipping.
- Do not discard the packing material until you have carefully inspected and satisfactorily operated the tool.
- If any parts are damaged or missing, please call 1-866-539-1710 for assistance.

ASSEMBLY

⚠ WARNING:

The tool should never be connected to a power supply when you are assembling parts, making adjustments, cleaning, performing maintenance, or when the tool is not in use. Disconnecting the tool will prevent accidental starting that could cause serious injury.

INSTALLING AUXILIARY HANDLE

See Figure 2.

An auxiliary handle is packed with the drill for ease of operation and to help prevent loss of control.

To install the auxiliary handle:

- Open the clamping ring by turning the handle counterclockwise.
- Slide the ring of the auxiliary handle onto the spindle collar of the machine.
- Tighten the auxiliary handle at the desired angle by turning the handle clockwise.

Note: For convenience the screw has been trapped inside the auxiliary handle.

To prevent thread damage and possible loss of control, the auxiliary handle should be checked periodically for tightness. Do not operate the drill with the handle loose.

INSTALLING THE DEPTH GAUGE ROD

See Figure 3.

Follow these steps to install the depth gauge rod.

- Lock the switch trigger by placing the rotation selector in the center position.
- Loosen the auxiliary handle assembly by turning the knob counterclockwise.
- Insert the depth gauge rod as shown in figure 3.
- Tighten the auxiliary handle assembly by turning the knob clockwise.

PACKING LIST

Hammer Drill with Auxiliary Handle Assembly
Depth Gauge Rod
Carrying Case
Operator's Manual

⚠ WARNING:

If any parts are missing do not operate this tool until the missing parts are replaced. Failure to do so could result in possible serious personal injury.

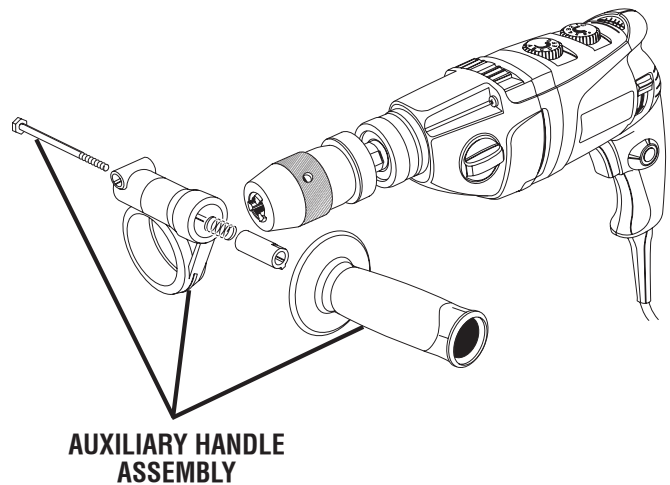

Fig. 2

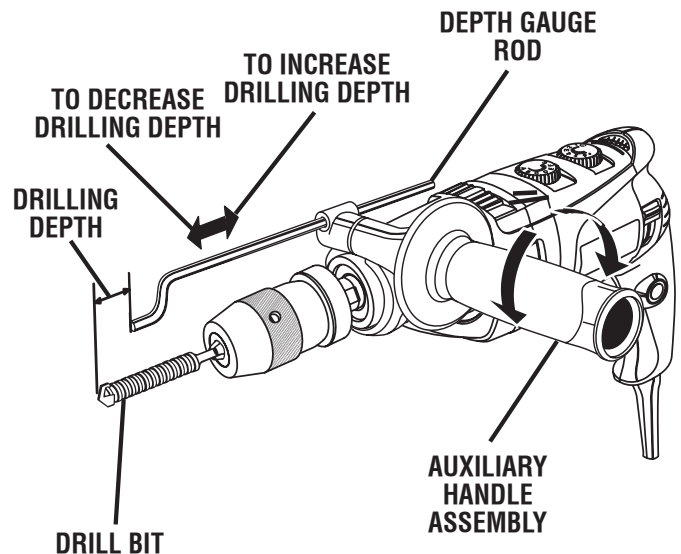

Fig. 3

ASSEMBLY

TO INSTALL BITS

See Figures 4 and 5.

- Unplug the drill.
- Open or close the chuck jaws to a point where the opening is slightly larger than the drill bit you intend to use. Also, raise the front of the drill slightly to keep the drill bit from falling out of the chuck jaws.
- Insert drill bit into chuck the full length of the jaws.

⚠ WARNING:

Do not insert drill bit into chuck jaws and tighten as shown in figure 5. This could cause drill bit to be thrown from the drill resulting in possible serious personal injury or damage to your chuck.

- Tighten the chuck jaws on drill bit.
- To tighten: grasp the chuck collar and rotate it to the right. Release the chuck collar and then turn the chuck body to the left.

Note: Rotate the chuck body in the direction of the arrow marked **GRIP** to tighten chuck jaws.

- **Do not** use a wrench to tighten or loosen the chuck jaws.

TO REMOVE BITS

- Unplug the drill.

Note: The lock will engage when trying to use the drill to open the chuck. For proper function, the rear sleeve must be unlocked prior to releasing the bit.

- Loosen the chuck jaws from drill bit.
- To loosen: grasp the chuck collar and rotate it to the left. Release the chuck collar and then turn the chuck body to the right.

Note: Rotate the chuck body in the direction of the arrow marked **RELEASE** to loosen chuck jaws.

- **Do not** use a wrench to tighten or loosen the chuck jaws.

- Remove drill bit from chuck jaws.

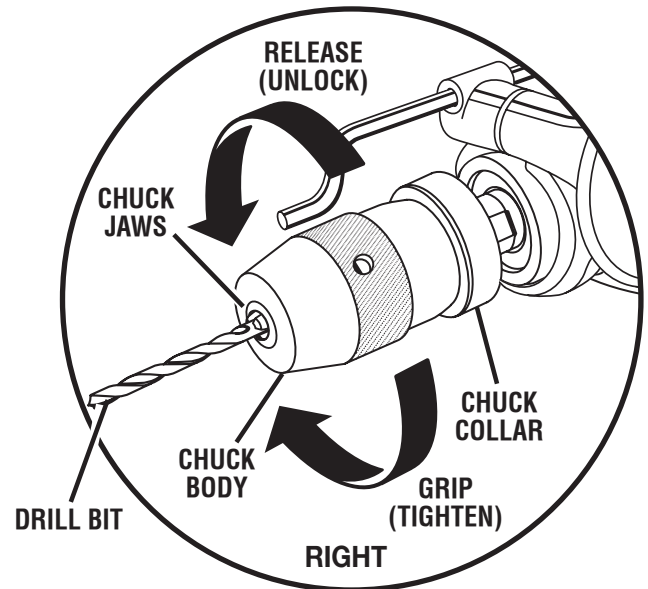

Fig. 4

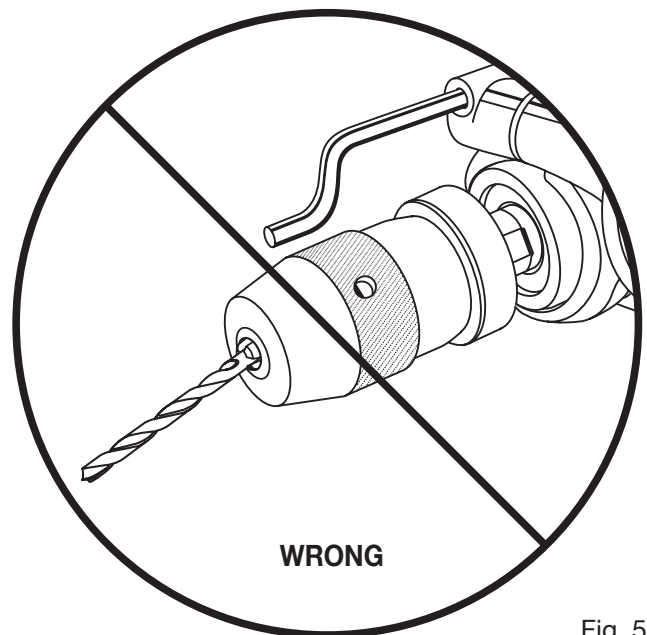

Fig. 5

OPERATION

⚠ WARNING:

Exercise caution when using this tool. Careless actions, for even a fraction of a second, can result in serious personal injury.

⚠ WARNING:

Always wear safety goggles or safety glasses with side shields when operating this tool. Failure to do so could result in dust, shavings, or loose particles being thrown into your eyes, resulting in possible serious injury.

APPLICATIONS

(Use only for the purpose listed below)

- Hammer drilling in concrete, brick, or other masonry.
- Drilling in wood.
- Drilling in ceramics, plastics, fiberglass, and laminates.
- Drilling in both soft and hard metals.
- Driving screws with screwdriver bits, using driving accessories.
- Mixing paint.

SWITCH

See Figure 6.

To turn the drill **ON**, depress the switch trigger. Release switch trigger to turn the drill **OFF**.

LOCK-ON BUTTON

See Figure 6.

The drill is equipped with a lock-on feature, which is convenient when continuous drilling for extended periods of time is required. To lock-on, depress the switch trigger, push in and hold the lock-on button located on the side of the handle, then release switch trigger. Release lock-on button and the drill will continue running.

To release the lock, depress the switch trigger and release.

If you have the lock-on feature engaged during use and the drill becomes disconnected from power supply, disengage the lock-on feature immediately.

⚠ WARNING:

To avoid loss of control or serious personal injury, when drilling in lock-on mode, keep your hand positioned on the switch and use the auxiliary handle. This will allow you to stop the drill immediately in case binding occurs.

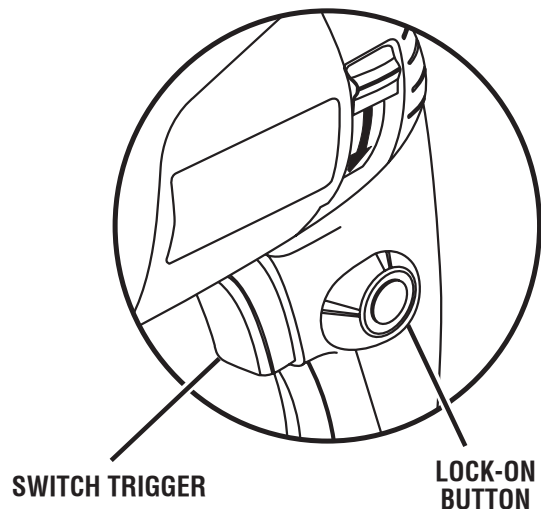

Fig. 6

KEYLESS CHUCK

See Figure 4.

This drill has a keyless chuck. As the name implies, you can hand tighten or release the drill bit in the chuck jaws. To loosen, grip the chuck collar and turn the chuck body counterclockwise. To tighten, grip the chuck collar and turn the chuck body clockwise. The arrows shown in figure 3 indicate which direction to rotate the chuck body in order to **GRIP** (tighten) or **RELEASE** (unlock) the drill bit. To lock or unlock the chuck, turn the chuck collar opposite the direction of the arrows while gripping the chuck body.

⚠ WARNING:

Do not hold the chuck body with one hand and use the power of the drill to tighten chuck jaws on drill bit. The chuck body could slip in your hand or your hand could slip and come in contact with a rotating drill bit. This could cause an accident resulting in serious personal injury.

OPERATION

REVERSIBLE

See Figure 7.

The drill has the feature of being reversible. The direction of chuck rotation is controlled by a switch located on either side of the drill housing.

The design of the switch will not permit changing the direction of rotation while the drill is running. Release the switch trigger and allow the drill to stop before changing its direction.

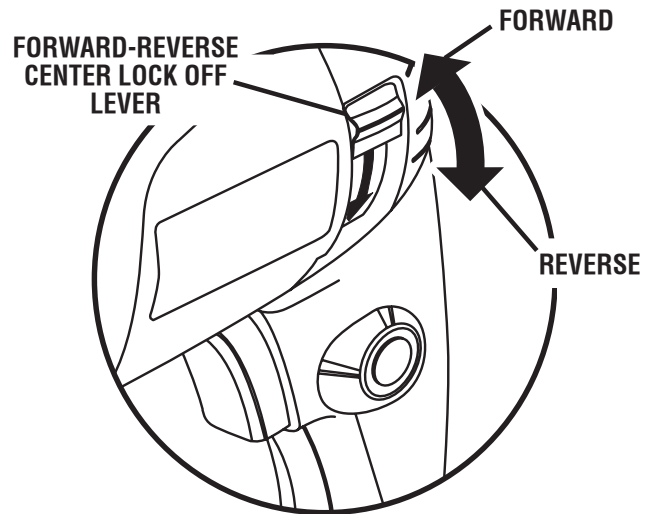

Fig. 7

VARIABLE SPEED

See Figures 8 and 12.

The drill has a variable speed dial designed to allow operator control of speed limits. The speed of the drill can be increased by turning the dial on top of the drill in a clockwise direction.

Avoid running the drill at low speeds for extended periods of time. Running at low speeds under constant usage may cause the drill to become overheated. If this occurs, cool the drill by running it without a load and at full speed.

The following guidelines may be used in determining correct speed for various applications:

- **Low** speed is ideal when minimum speed and power is required. For example, starting holes without center punching, driving screws, mixing paint, and drilling in ceramics.
- **Medium** speed is suitable for drilling hard metals, plastics, and laminates.
- **High** speed produces best results when maximum power is required. For example, drilling in wood; soft metals such as aluminum, brass, and copper, and when using driving accessories.

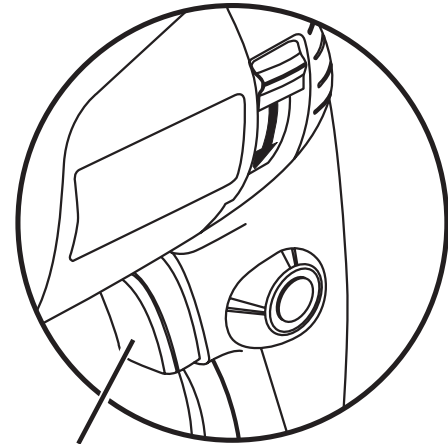

TO INCREASE SPEED,
PULL SWITCH TRIGGER

Fig. 8

CAUTION:

Never change gears while the tool is running. Failure to obey this caution could result in serious damage to the drill.

TWO-SPEED GEAR SHIFT KNOB

See Figure 9.

The hammer drill has a two-speed gear shift knob which provides a high speed of approximately 3,000 RPM and a low speed of approximately 1,000 RPM (stated speeds are with the switch trigger in "Full-On" position).

For high speed operation, rotate two-speed gear shift knob clockwise aligning with indicating mark on knob. For low speed operation, rotate knob counterclockwise with indicating mark on knob. It may be necessary to rotate the chuck by hand while rotating knob.

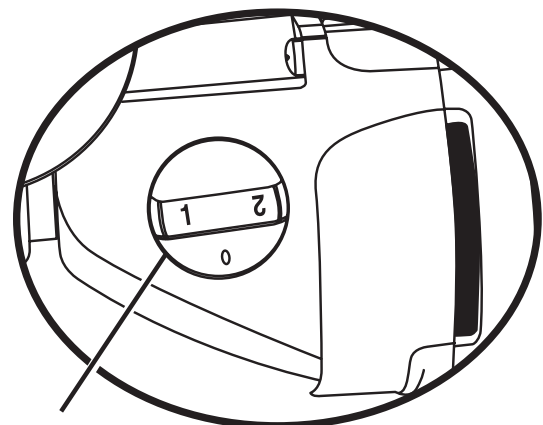

TWO-SPEED
GEAR SHIFT KNOB

Fig. 9

OPERATION

DRILLING

See Figure 10.

- Attach auxiliary handle.

⚠ WARNING:

Do not force the tool. Forcing the tool can result in jamming and loss of balance or footing, which could result in personal injury.

- Depress and release switch trigger to be sure the drill is in **OFF** position before connecting it to power supply.
 - Check the direction of rotation lever for correct setting (forward or reverse). See Figure 7.
 - Secure the material to be drilled in a vise or with clamps to keep it from turning as the drill bit rotates.
 - Plug the drill into power supply source.
 - Hold the drill firmly and place bit at the point to be drilled.
-

⚠ WARNING:

To avoid loss of control or serious personal injury, always use both hands when operating this tool. Grip the auxiliary handle firmly with one hand and grip the switch handle of the tool with the other hand.

- Depress the switch trigger to start the drill. Do not lock the switch **ON** for jobs where the drill may need to be stopped suddenly.
 - Move the drill bit into the workpiece applying only enough pressure to keep the bit cutting. Do not force the drill or apply side pressure to elongate a hole. Let the drill and bit do the work.
-

⚠ WARNING:

Be prepared for binding or bit breakthrough. When these situations occur, drill has a tendency to grab and kick opposite to the direction of rotation and could cause loss of control when breaking through materials. If not prepared, this loss of control can result in possible serious injury.

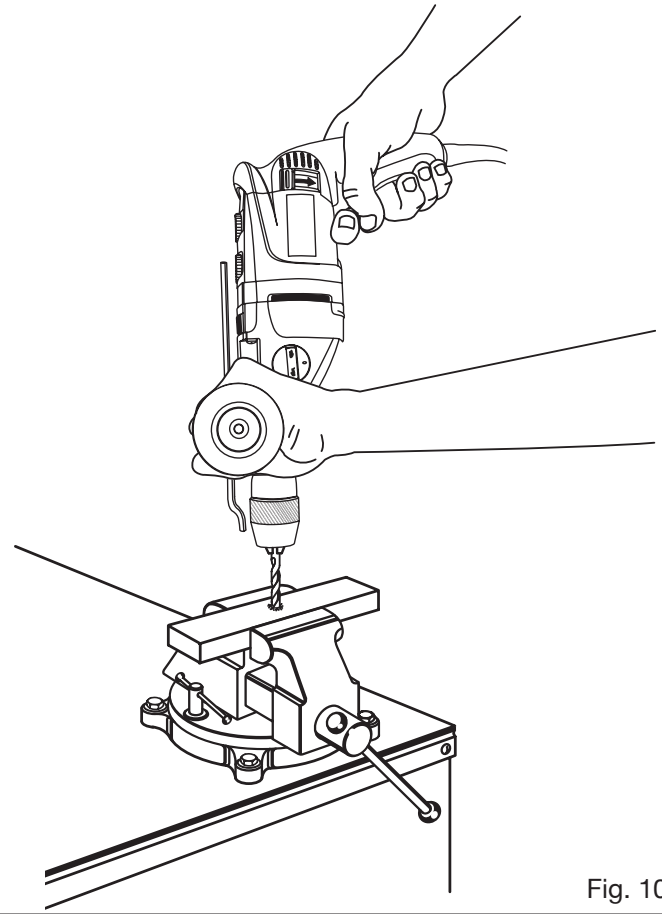

Fig. 10

HELPFUL HINTS

When drilling hard, smooth surfaces use a center punch to mark the desired hole location. This will prevent the drill bit from slipping off center as the hole is started. However, the variable speed feature allows starting holes without center punching if desired. To accomplish this, operate the drill at a low speed until the hole is started.

Pulse mode allows you to drill on hard surfaces without a center punch.

When drilling metals use a light oil on the drill bit to keep it from overheating. The oil will prolong the life of the bit and increase the drilling action.

If the bit jams in the work piece or if the drill stalls, stop the tool immediately. Remove the bit from the work piece and determine the reason for jamming.

ADJUSTMENTS

ADJUSTING THE AUXILIARY HANDLE ASSEMBLY

See Figure 11.

Follow these steps to adjust the auxiliary handle assembly.

- Loosen the auxiliary handle assembly by turning the knob counterclockwise.
- Rotate the auxiliary handle assembly to the desired location.
- Tighten the auxiliary handle assembly securely by turning the knob clockwise.

ADJUSTING DRILLING MODE

See Figure 12.

To adjust for type of drilling, slide adjustment button on top of motor housing hammer mode or drilling mode. For your convenience a hammer symbol and drill bit symbol have been molded into the adjustment button.

⚠ WARNING:

The hammer drill has not been designed for reverse hammering.

We recommend that you use carbide-tipped bits and select hammer mode when drilling in hard materials such as brick, tile, concrete, etc.

We recommend that you select normal drill mode when drilling with twist drills, hole saws, etc., in soft material.

Pulse mode is activated when rear dial on top of drill is turned to the circle icon and can be used at any RPM (high or low speed). Numbers 1 through 6 on the same dial are the torque settings.

VARIABLE TORQUE/PULSE

See Figure 12.

The adjustable torque is controlled by a dial on top of the drill and numbered 1-6, with 1 being the lowest and 6 the highest. Rotate the dial clockwise to increase torque. Always reduce the torque setting when there is a risk of the bit grabbing, such as at "break through." The "+" setting is the maximum torque setting.

The pulse feature is used to help start holes without use of a center punch. Pulse mode drilling allows for working with damaged screw heads, countersinking screws in wood, unscrewing very tight screws, and starting a drill bit on hard, smooth surfaces.

The torque control dial is in the "pulse" mode when turned to the full counterclockwise position.

ADJUSTING THE DEPTH GAUGE ROD

See Figure 13.

Follow these steps to adjust the depth gauge rod.

- Lock the switch trigger by placing the rotation selector in the center position.
- Loosen the auxiliary handle assembly by turning the knob counterclockwise.

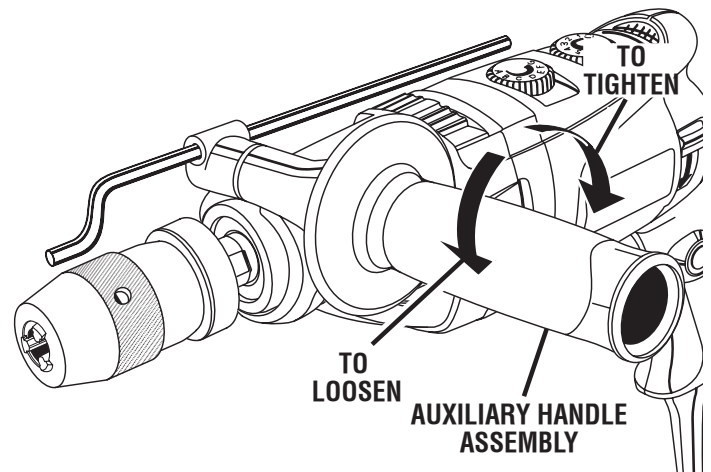

Fig. 11

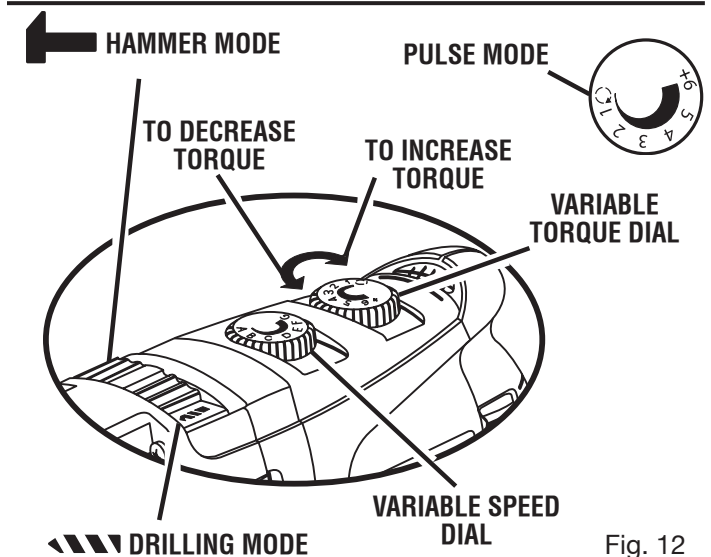

Fig. 12

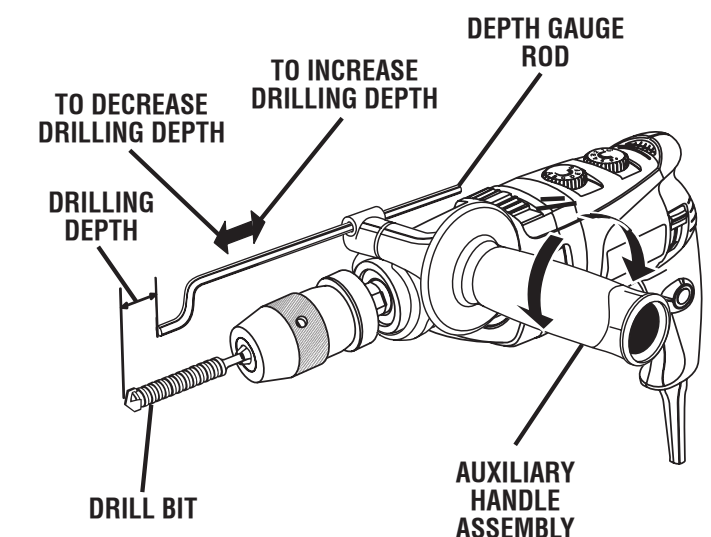

Fig. 13

- Adjust the depth gauge rod so that the drill bit extends beyond the end of the rod to the required drilling depth.
- Tighten the auxiliary handle assembly by turning the knob clockwise.

MAINTENANCE

⚠ WARNING:

The tool should never be connected to a power supply when you are assembling parts, making adjustments, cleaning, performing maintenance, or when the tool is not in use. Disconnecting the tool will prevent accidental starting that could cause serious injury.

CHUCK REMOVAL

See Figure 14.

To remove the chuck:

- Unplug the drill.
- Using two open-end wrenches, loosen the chuck. See Figure 14.
- This will loosen the chuck on the spindle. It can now be unscrewed by hand.

TO RETIGHTEN A LOOSE CHUCK

See Figure 15.

The chuck may at times become loose on the spindle and develop a wobble. To tighten, follow these steps:

- Unplug the drill.
- Using two open-end wrenches, tighten the chuck. See Figure 15.
- This will tighten the chuck on the spindle.

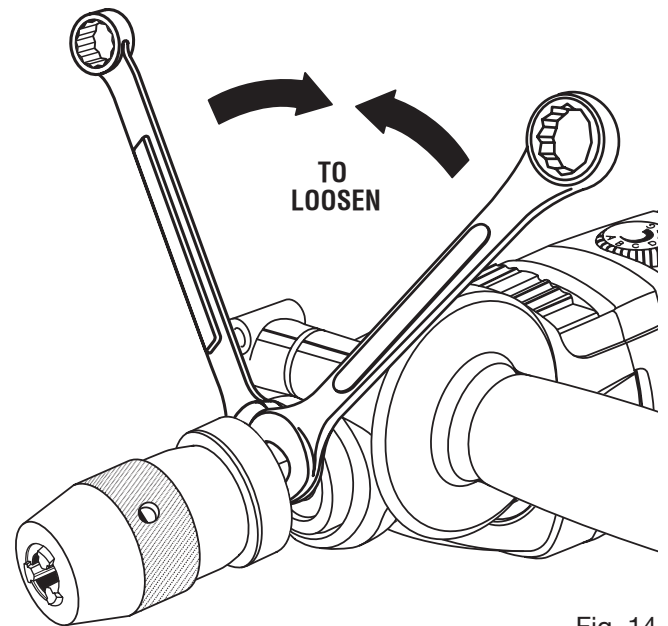

Fig. 14

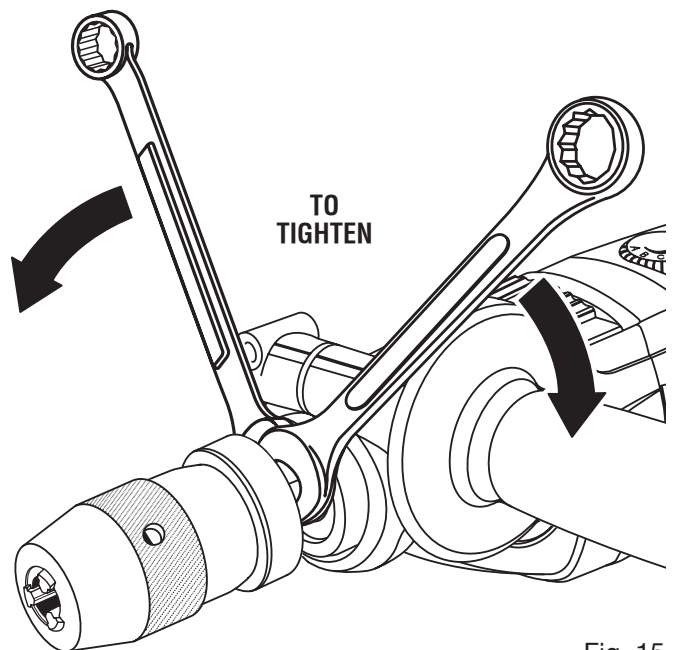

Fig. 15

MAINTENANCE

⚠ WARNING:

When servicing use only identical RIDGID® replacement parts. Use of any other parts may create a hazard or cause product damage.

Do not abuse power tools. Abusive practices can damage tool as well as workpiece.

⚠ WARNING:

The tool should never be connected to a power supply when you are assembling parts, making adjustments, cleaning, performing maintenance, or when the tool is not in use. Disconnecting the tool will prevent accidental starting that could cause serious injury.

GENERAL

Use clean cloths to remove dirt, carbon dust, etc.

⚠ WARNING:

Do not at any time let brake fluids, gasoline, petroleum-based products, penetrating oils, etc. come in contact with plastic parts. They contain chemicals that can damage, weaken, or destroy plastic.

Electric tools used on fiberglass material, wallboard, spackling compounds, or plaster are subject to accelerated wear and possible premature failure because the fiberglass chips and grindings are highly abrasive to bearings, brushes, commutators, etc. Consequently, we do not recommend using this tool for extended work on these types of materials. However, if you do work with any of these materials, it is extremely important to clean the tool using compressed air.

⚠ WARNING:

Always wear safety goggles or safety glasses with side shields during power tool operation or when blowing dust. If operation is dusty, also wear a dust mask.

LUBRICATION

All of the bearings in this tool are lubricated with a sufficient amount of high grade lubricant for the life of the tool under normal operating conditions. Therefore, no further lubrication is required.

WARRANTY

RIDGID® HAND HELD AND STATIONARY POWER TOOL

LIMITED THREE YEAR WARRANTY AND 90-DAY SATISFACTION GUARANTEE POLICY

This product is manufactured by One World Technologies, Inc., under a trademark license from Ridgid, Inc. All warranty communications should be directed to One World Technologies, Inc., attn: RIDGID handheld and stationary power tool technical service at (toll free) 1-866-539-1710.

90-DAY SATISFACTION GUARANTEE POLICY

During the first 90 days after the date of purchase, if you are dissatisfied with the performance of this RIDGID tool for any reason you may return the tool to the dealer from which it was purchased for a full refund or exchange. To receive a replacement tool you must present proof of purchase and return all original equipment packaged with the original product. The replacement tool will be covered by the limited warranty for the balance of the three year warranty period.

WHAT IS COVERED UNDER THE LIMITED THREE YEAR WARRANTY

This warranty covers all defects in workmanship or materials in this RIDGID tool for the three year period from the date of purchase. This warranty is specific to this tool. Warranties for other RIDGID products may vary.

HOW TO OBTAIN SERVICE

To obtain service for this RIDGID tool you must return it, freight prepaid, to an authorized RIDGID service center for hand held and stationary power tools. You may obtain the location of the authorized service center nearest you by calling (toll free) 1-866-539-1710 or by logging on to the RIDGID website at www.ridgid.com. When requesting warranty service, you must present the proof of purchase documentation, which includes a date of purchase. The authorized service center will repair any faulty workmanship, and either repair or replace any defective part, at our option at no charge to you.

WHAT IS NOT COVERED

This warranty applies only to the original purchaser at retail and may not be transferred. This warranty only covers defects arising under normal usage and does not cover any malfunction, failure or defect resulting from misuse, abuse, neglect, alteration, modification or repair by other than an authorized service center for RIDGID branded hand held and stationary power tools. **RIDGID, INC. AND ONE WORLD TECHNOLOGIES, INC. MAKE NO WARRANTIES, REPRESENTATIONS OR PROMISES AS TO THE QUALITY OR PERFORMANCE OF ITS POWER TOOLS OTHER THAN THOSE SPECIFICALLY STATED IN THIS WARRANTY.**

ADDITIONAL LIMITATIONS

To the extent permitted by applicable law, all implied warranties, including warranties of MERCHANTABILITY or FITNESS FOR A PARTICULAR PURPOSE, are disclaimed. Any implied warranties, including warranties of merchantability or fitness for a particular purpose, that cannot be disclaimed under state law are limited to three years from the date of purchase. One World Technologies, Inc. is not responsible for direct, indirect, incidental or consequential damages. Some states do not allow limitations on how long an implied warranty lasts and/or do not allow the exclusion or limitation of incidental or consequential damages, so the above limitations may not apply to you. This warranty gives you specific legal rights, and you may also have other rights which vary from state to state.

One World Technologies, Inc.
Hwy. 8
Pickens, SC 29671
