



Assembly & Instruction Manual **ITEM 3612**



2 TON ENGINE HOIST CHERRY PICKER

THANK YOU FOR BUYING CUMMINS INDUSTRIAL TOOLS
You can purchase additional items at
www.cumminstools.com

SAVE THIS MANUAL FOR FUTURE REFERENCE



Customer Service Postal Address:
1290 35 Road
Minden, NE 68959
Voice: 1-(308) 832-2070
Fax: 1-(308) 832-2069

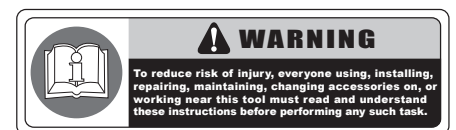

Your new 2 Ton Cherry Picker has been engineered and manufactured to Cummins Industrial Tools high standards for dependability, ease of operation, and operator safety. Pay close attention to the Rules for Safe Operation, Warnings, and Cautions. If you use your machine properly and only for what it is intended, you will enjoy years of safe, reliable service.

SAFETY WARNINGS AND PRECAUTIONS

WARNING: When using tool, basic safety precautions should always be followed to reduce the risk of personal injury and damage to equipment. Read all instructions before using the tool!

- **Work area conditions.** Cluttered areas invite injuries.
- **Additional work area conditions.** Do not use machines or power tools in damp or wet locations. Do not expose to rain. Keep work area well lighted.
- **Keep children away.** Children must never be allowed in the work area. Do not let them handle machines, tools or extension cords.
- **Store idle equipment.** When not in use, tools must be stored in a dry location to inhibit rust. Always lock up tools and keep out of reach of children.
- **Use the right tool for the job.** Do not attempt to force a small tool or attachment to do the work of a larger industrial tool. There are certain applications for which this tool was designed. It will do the job better and more safely at the rate for which it was intended. Do not modify this tool and do not use this tool for a purpose for which it was not intended.
- **Dress properly.** Do not wear loose clothing or jewelry as they can be caught in moving parts. Protective, electrically non-conductive clothes and non-skid footwear are recommended when working. Wear restrictive hair covering to contain long hair.
- **Use eye protection.** Always wear ANSI approved impact safety glasses underneath a full face shield during use. Also, wear heavy duty work gloves.
- **Do not overreach.** Keep proper footing and balance at all times. Do not reach over or across running machines.
- **Maintain tools with care.** Keep tools sharp and clean for better and safer performance. Follow instructions for lubricating and changing accessories. The handles must be kept clean, dry, and free from oil and grease at all times.
- **Remove adjusting keys and wrenches.** Check that keys and adjusting wrenches are removed from the tool or machine work surface before starting work.
- **Stay alert.** Watch what you are doing, use common sense. Do not operate any tool when you are tired.
- **Check for damaged parts.** Before using any tool, any part that appears damaged should be carefully checked to determine that it will operate properly and perform its intended function. Any part that is damaged should be replaced.
- **Replacement parts and accessories.** When servicing, use only identical replacement parts. Use of any other parts will void the warranty. Only use accessories intended for use with this tool. Approved accessories are available from Cummins Industrial Tools.
- **Do not operate tools if under the influence of alcohol or drugs.** Read warning labels on prescriptions to determine if your judgment or reflexes are impaired while taking drugs. If there is any doubt, do not operate the tool.

WARNING: The warnings, cautions, and instructions discussed in this instruction manual can not cover all possible conditions and situations that may occur. It must be understood by the operator that common sense and caution are factors which can not be built into this product, but must be supplied by the operator.

OPERATING INSTRUCTIONS

Assembly

For safety and ease of assembly, use two people to assemble the Cherry Picker.

WARNING: To ensure safe operation, it is ESSENTIAL that the correct bolts are used during assembly. If an improper bolt is used, this unit could fail, potentially causing SERIOUS PERSONAL INJURY or DEATH.

- **Step 1.** Attached two 3-1/2" SWIVEL CASTER(9) and two 3" SWIVEL CASTER (10) to base frame using BOLTS (21), NUT (30) and LOCK WASHERS (31) . Using four RING PINS (5), assemble the LEGS (4) to the BASE ASSEMBLY (1).

Note: To insert the front RING PINS (5), lift up on the front of the BASE ASSEMBLY (1) until the holes line up. After all four RING PINS (5) are inserted; insert one HAIR PIN (17) though the small hole the end of each of the RING PINS (5) until it snaps into place.

Make sure that all RING PINS (5) are secure before proceeding.

- **Step 2.** Using the BOLTS (19), FLAT WASHERS (26), and NUTS (25) secure the POST (3) to the BASE ASSEMBLY (1).
- **Step 3.** Assemble the SUPPORTS (6) to the BASE ASSEMBLY (1) using the two BOLTS (14), FLAT WASHERS (24) and NUTS (23) for the bottom of the SUPPORTS (6) and the BOLT (16), WASHER (24), and NUT (23) for the top.
- **Step 4.** Place the BOOM (2) onto the POST (3) and secure with BOLT (15), FLAT WASHER (24) and NUT (23).
- **Step 5.** Assemble the lower end of the JACK (11) to the POST (3) using the BOLT (17), FLAT WASHER (24) and NUT (23).
- **Step 6.** Secure the top of the JACK (11) to the BOOM (2) using BOLT (18), WASHER (24) and NUT (23).
- **Step 7.** Slide the BOOM EXTENSION (32) into the BOOM (2). And secure it by using BOLT (19), FLAT WASHER (26) and NUT (25) at the desired load rating.
- **Step 8.** Attach the HOOK & CHAIN (8) to the end of the BOOM EXTENSION (32) using BOLT (20), FLAT WASHER (28) and LOCK WASHER (29) and NUT (27).

OPERATING INSTRUCTIONS

Operation

Note: Not to be used for aircraft pupose.

- **Step 1.** Adjust the BOOM EXTENSION (32) to a weight limit position that exceeds the weight you will be lifting. Securely tighten the BOLT (19), FLAT WASHER (26) and NUT (25).

CAUTION: DO NOT MOVE THE CHERRY PICKER WHEN UNDER LOAD. The Casters are not designed to be rolled when the Cherry Picker is lifting heavy objects.

- **Step 2.** Move the Cherry Picker so that the HOOK & CHAIN (8) is directly above the item to be lifted.
- **Step 3.** Securely attach the HOOK & CHAIN to the item.
- **Step 4.** To raise the BOOM (2), turn the JACK (11) release valve fully clockwise (right). Insert the HANDLE (12) into the JACK and pump (up and down) repeatedly until the item has been lifted to the desired height.
- **Step 5.** To lower the Cherry Picker, SLOWLY turn the JACK release valve counterclockwise (left).

Folding the Frame

NOTE: Do not fold Cherry Picker while it is loaded.

- **Step 1.** Lower Cherry Picker all the way.
- **Step 2.** Remove HAIR PINS (7) from the front RING PINS (5). Remove the front RING PINS (5). Leave the rear RING PINS (5) in.
- **Step 3.** Raise LEG (4) until it rests against HANDLE (12).
- **Step 4.** Insert a front RING PIN into the middle hole of the BASE ASSEMBLY (1).

Note; Be certain that, when unfolding, both RING PINS (5) and HAIRPINS (7) are placed back in the proper places.

PARTS LIST

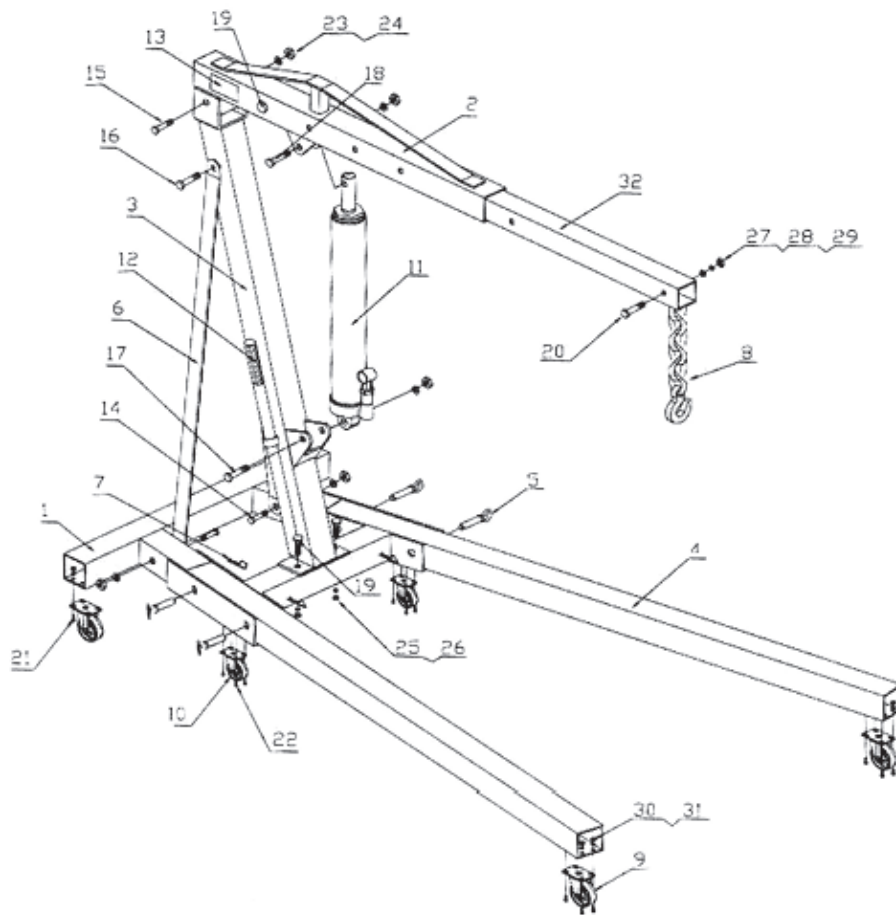

Parts list

REF	DESCRIPTION	QTY	REF NO	DESCRIPTION	QTY
1	Base Assembly	1	17	Bolt M16X90	1
2	Boom	1	18	Bolt M16X80	1
3	Post	1	19	Bolt M14X100	3
4	Leg	2	20	Bolt M12X80	1
5	Ring Pin	4	21	Bolt M8X20	16
6	Support	2	22	Bolt M8X12	8
7	Hair Pin	4	23	Nut M16	6
8	Hook and Chain	1	24	Flat Washer016	6
9	3-1/2" Swivel Casters	4	25	Nut M14	3
10	3" Swivel Casters	2	26	Flat Washer014	3
11	Jack	1	27	Nut M12	1
12	Handle	1	28	Flat Washer012	1
13	Warning Label	1	29	Lock Washer012	1
14	Bolt M16X100	2	30	Nut M8	24
15	Bolt M6X120	1	31	Lock Washer08	24
16	Bolt M16X110	1	32	Boom Extension	1