

TABLE OF CONTENTS

■ Introduction	1
■ General Safety Rules	2
■ Specific Safety Rules	3-6
■ Unpacking	6
■ Product Specifications	7
■ Installation	8
■ Operation	9
■ Maintenance	9
■ Exploded Diagram	10
■ Partrs List	10

INTRODUCTION

- THIS PRODUCT has many features for making the use of this product more pleasant and enjoyable. Safety, performance, and dependability have been given top priority in the design of this product making it easy to maintain and operate.

▲ WARNING: Do not attempt to use this product until you thoroughly read and completely understand the operator's manual. Pay close attention to the safety rules, including Dangers, Warnings, and Cautions. If you use your product properly and only as intended, you will enjoy years of safe, reliable service.

- ▲** Look for this symbol to point out important safety precautions. It means attention!!! Your safety is involved.



▲ WARNING: The operation of any tool can result in foreign objects being thrown into your eyes, which can result in severe eye damage. Before beginning operation, always wear safety goggles or safety glasses with side shields and a full face shield when needed. We recommend Wide Vision Safety Mask for use over eyeglasses or standard safety glasses with side shields. Always wear eye protection which is marked to comply with ANSI Z87.1.

GENERAL SAFETY RULES

⚠ WARNING: When using tool, basic safety precautions should always be followed to reduce the risk of personal injury and damage to equipment. Read all instructions before using the tool!

- **Work area conditions.** Cluttered areas invite injuries.
- **Additional work area conditions.** Do not use machines or power tools in damp or wet locations. Do not expose to rain. Keep work area well lighted.
- **Keep children away.** Children must never be allowed in the work area. Do not let them handle machines, tools or extension cords.
- **Store idle equipment.** When not in use, tools must be stored in a dry location to inhibit rust. Always lock up tools and keep out of reach of children.
- **Use the right tool for the job.** Do not attempt to force a small tool or attachment to do the work of a larger industrial tool. There are certain applications for which this tool was designed. It will do the job better and more safely at the rate for which it was intended. Do not modify this tool and do not use this tool for a purpose for which it was not intended.
- **Dress properly.** Do not wear loose clothing or jewelry as they can be caught in moving parts. Protective, electrically non-conductive clothes and non-skid footwear are recommended when working. Wear restrictive hair covering to contain long hair.
- **Use eye protection.** Always wear ANSI approved impact safety glasses underneath a full face shield during use. Also, wear heavy duty work gloves.
- **Do not overreach.** Keep proper footing and balance at all times. Do not reach over or across running machines.
- **Maintain tools with care.** Keep tools sharp and clean for better and safer performance. Follow instructions for lubricating and changing accessories. The handles must be kept clean, dry, and free from oil and grease at all times.
- **Remove adjusting keys and wrenches.** Check that keys and adjusting wrenches are removed from the tool or machine work surface before starting work.
- **Stay alert.** Watch what you are doing, use common sense. Do not operate any tool when you are tired.
- **Check for damaged parts.** Before using any tool, any part that appears damaged should be carefully checked to determine that it will operate properly and perform its intended function. Any part that is damaged should be replaced.
- **Replacement parts and accessories.** When servicing, use only identical replacement parts. Use of any other parts will void the warranty. Only use accessories intended for use with this tool. Approved accessories are available from Cummins Industrial Tools.
- **Do not operate tools if under the influence of alcohol or drugs.** Read warning labels on prescriptions to determine if your judgment or reflexes are impaired while taking drugs. If there is any doubt, do not operate the tool.

⚠ WARNING: The warnings, cautions, and instructions discussed in this instruction manual can not cover all possible conditions and situations that may occur. It must be understood by the operator that common sense and caution are factors which can not be built into this product, but must be supplied by the operator.

SPECIFIC SAFETY RULES

⚠ WARNING: Observe safety precautions for personal safety and the safety of others. Careless winch operation may cause serious personal injury and equipment damage.

- Read the following carefully before attempting to operate your winch and keep the instructions for future reference.

Dress properly:

- Don't wear loose clothing or jewellery. They can be caught in moving parts.
- Always wear leather gloves when handling winch wire rope. Do not handle cable with bare hands as broken wires can cause injuries.
- Non-skid footwear is recommended.
- Protective hair covering to contain long hair.

Keep a safe distance:

- Ensure that all persons stand well clear of winch wire rope and load during winching operation, Keep helpers and spectators at a safe distance, 1.5 times the cable length recommended. If a wire rope pulls loose or breaks under load it can lash back with tremendous force and cause serious personal injury or death.
- Don't step over the wire rope.
- All visitors and onlookers should be kept away from the work area.
- Keep proper footing and balance at all times.

Don't abuse the cord:

- Never carry out winch by the cord or yank it to disconnect it from the receptacle.
- Keep cord from heat, oil and sharp edges.

Don't overload the winch:

- This winch is rated for intermittent duty. If the motor becomes uncomfortably hot to touch, stop and let it cool down for a few minutes. The cool down period can be used to recharge the battery.
- Don't maintain power to the winch if the motor stalls.
- Don't exceed maximum line pull ratings shown in tables. Double line with a Snatch Block to reduce the load on the winch and wire rope by almost half. Avoid shock loads exceed the winch and wire rope rating.

Avoid unintentional starting:

- Winch clutch should be disengaged when not in use and fully engaged when in use.

Check damaged parts:

- Before using, you should check your winch carefully. Any part that is damaged should be properly repaired or replaced by an authorized service center.

Repair your winch:

- When repairing, use only identical replacement parts or it may cause considerable danger for the user.

SPECIFIC SAFETY RULES

Respool the wire rope:

- Leather gloves must be worn while respooling. To respool correctly, it is necessary to keep a slight load on the wire rope. Hold the wire rope with one hand and the remote control switch with the other. Start as far back and in the center as you can. Walk up keeping load on the wire rope as the winch is powered in.
- Do not allow the wire rope to slip through your hand and do not approach the winch too closely.
- Turn off the winch and repeat the procedure until all the cable except 3 to 4 feet is in.
- Disconnect the remote control switch and finish spooling in wire rope by rotating the drum by hand with clutch disengaged.
- On hidden winches, spool in wire rope under power but keep hands clear.

⚠ CAUTION: The use of any other accessory or attachment other than those recommended in the instruction manual may present risk of personal injury.

Winch Operation Warning

- **Read the following carefully before attempting to operate your winch and keep the instructions for future reference.**
- The uneven spooling of wire rope, while pulling a load, is not a problem, unless there is a wire rope pile up on one end of the drum. If this happens reverse the winch to relieve the load and move your anchor point further to the center of the vehicle. After the job is done you can unroll and rewind for a neat layer of the wire rope.
- Store the remote control switch inside your vehicle where it will not be damaged. Inspect it before you plug it in. Don't leave the switch plugged in when winch is not in use.
- When ready to begin spooling in, plug in remote control switch with clutch disengaged. Do not engage clutch with motor running.
- While the remote control lead is plugged into the winch, always keep clear of the drum and fairlead area and the wire rope and rigging.
- Never connect the hook back to the wire rope itself. This causes damage to the wire rope. Always use a sling or chain of suitable strength.
- Observe the winch while operating. Try to maintain a safe distance. Stop the winching process every foot or so to assure the wire rope is not pulling up in one corner. Jamming the wire rope can break your winch.
- Do not attach tow hooks to winch mounting apparatus. They must be attached to vehicle frame.
- The use of a snatch block will aid recovery operation by providing a doubling of the winch capacity and a halving of the winching speed, and the means to maintain a direct line pull to the center of the rollers. When double loading during stationary winching, the winch hook should be attached to the chassis of the vehicle.
- Ensure rated "D" or bow shackle are used in conjunction with an approved tree trunk protector to provide a safe anchor point.

SPECIFIC SAFETY RULES

- When extending winch wire rope, ensure that at least five wraps of wire rope remain on drum at all times. Failure to do so could result in the wire rope parting from the drum under load. Serious personal injury or property damage may result.
- All winches are provided with a Red Cable marking to identify that 5 wire rope wraps remain on the winch drum when this mark appears at the rollers. No recovery should be attempted beyond this marking.
- Since the greatest pulling power is achieved on the innermost layer of your winch, it is desirable to pull off as much line as you can for heavy pulls (you must leave at least 5 wraps minimum on the drum-red cable). If this is not practical use a snatch block and double line arrangement.
- Wrapping a heavy blanket or similar object over the extended winch wire rope is recommended as it will dampen any back lash should a failure occur.
- Neat, tight spooling avoids wire rope binding, which is caused when a load is applied and the wire rope is pinched between the others. If this happens, alternatively power the winch in and out. Do not attempt to work a bound wire rope under load, free by hand.
- Apply block to wheels when vehicles are on a slope.

Battery:

- Make sure that the battery is in good condition; all electrical connections are clean and tight. Avoid battery contact with acid or other contaminants.
- Always wear eye protection when working around a battery.
- Have the engine running when using the winch, to avoid draining the battery.

Winch Wire Rope:

- Be sure that the wire rope is in good condition and is attached properly.
- Never handle the wire rope or rigging while anyone else is at the control switch or during the winching operation.
- Never use the winch if wire rope is frayed, kinked or damaged.
- Never move the vehicle to pull a load.
- Never replace the wire rope with a wire rope of lesser strength.
- The life of wire rope is directly related to the use and care it receives. Following its first and subsequent uses, a wire rope must be wound on to the drum under a load of at least 500 lb (230 kg) or the outer wraps will draw into the inner wraps and severely damage the wire rope during winching. The first winch use should be a familiarization run while in a relaxed, non-recovery situation. Spool out the wire rope until the red wire rope mark appears (about five wraps on the drum), then rewind the wire rope on to the drum under a load of 500 lb (230 kg) or more. This will slightly tension and stretch the new wire rope and create a tight cable wrap around the drum. Failure to do so may result in wire rope damage and reduced wire rope life.
- At times it may be necessary to temporarily respool the wire rope under no load after use. The correct procedure is to hold the remote control lead in one hand and the wire rope in the other. Start as far from the vehicle as the remote control will allow, activate the switch, walk in several feet of rope and release the switch. Repeat the process. Always release the switch when your hand is at least four feet from the fairlead (the physical opening through which the wire rope passes).

SPECIFIC SAFETY RULES

⚠ CAUTION: When powering in wire rope during side pull operations, the wire rope will stack up at one end of the drum. Eventually this stack will become large enough to cause serious damage to winch. To prevent this damage, line pulls should be as straight in front of the vehicle as possible. Stop winching if the wire rope comes close to the tie rods or mounting plate. To correct an uneven stack, spool out the stacked section of the wire rope and reposition it to the opposite end of the drum. This will free up space for continued winching.

- Do not attempt to exceed the pulling limits of this winch.
- Do not drive your vehicle to assist the winch in any way. Vehicle movement in combination with winch operation may overload the cable, the winch itself or cause damaging shock loads.
- Shock loads when winching are dangerous! A shock load occurs when an increased force is suddenly applied to the cable. A vehicle rolling back on a slack cable may induce a damaging shock load.
- The winches shown in this manual are solely for vehicle and boat mounting and non-industrial applications.
- Do not use winch in hoisting applications due to required hoist safety factors and features.
- Do not use the winch to lift, support or otherwise transport personnel.

UNPACKING

INSTRUCTIONS

When unpacking the tool:

- Carefully remove the tool and accessories from the box.
- Make sure that all items listed in the packing list are included.
- Inspect the tool carefully to make sure no breakage or damage occurred during shipping.
- Do not discard the packing material until you have carefully inspected and satisfactorily operated the tool.

⚠ WARNING: If any part are missing do not operate the tool until the missing parts are replaced. Failure to do so could result in possible serious personal injury.

PRODUCT SPECIFICATIONS

■ Rated line pull	10000 lb (4536 kg) Single-line
■ Motor	3.6HP/2.7KW, Permanent Magnet DC 12V Motor
■ Control	Remote Switch, 12' (3.7 m) Lead
■ Gear Train	3-Stage Planetary
■ Gear Ratio	317.7:1
■ Clutch	Sliding Ring Gear
■ Brake	Automatic In-The-Drum
■ Drum size	Diameter 2.5" (63.5 mm), Length 8.8" (223 mm)
■ Wire Rope	95' Length, 3/8" Diameter (29 m Length, 9.2 mm Diameter)
■ Fairlead	4-Way Roller Fairlead
■ Remote Control	Included
■ Finish	Black/Dark gray
■ Overall dimensions	(L×W×H) 22"×6.3"×10" (560×160×254 mm)
■ Mounting Bolt Pattern	10"×4.5" (254×114 mm)

Line speed & Amp Draw-First Layer

Line Pull	Lb	0	4000	6000	8000	10000
	Kg	0	1814	2722	3629	4536
Line Speed	ft/min	9.3	6	4.7	3,7	3
	m/min	2,8	1.8	1.4	1.1	0.9
Motor Currency	AMPS	40	130	170	240	340

Line pull & Cable capacity

Layer of Cable		1	2	3	4
Rated line Pull per layer	Lb	10000	7964	6591	5632
	Kg	4532	3601	2987	2552
Cumulative capacity per layer	Ft	17	37	62	94
	M	5	11	19	28

ASSEMBLY

Mounting Your Winch

- 1- The winch is to be mounted into a suitable steel mounting frame using the 4 point foot mounting system in either a horizontal or a vertical plane.

It's very important that the winch be mounted on a flat surface so that the three sections (motor, cable drum and gear housing) are properly aligned.

Before commencing installation, ensure the mounting facility being used is capable of withstand the winch's rated capacity.

The fitment of winch and/or a frontal protection system may affect the triggering of airbags. Check that the mounting system has been tested and approved for winch fitment in the airbag equipped vehicle.

- 2- Should you wish to manufacture your own mounting plate, consult the dimensions recommended below. A steel mount plate $\frac{1}{4}$ in. thick is recommended. Fasteners should be steel high tensile grade 5 or better. A poorly designed mount voids the warranty.
- 3- The roller fairlead is is to be mounted so as to guide the rope onto the drum evenly.

Electrical Connection

- For normal self-recovery work, your existing electrical system is adequate. A fully charged battery and proper connections are essential. Run the vehicle engine during winching operations to keep battery charged.

Pay attention to proper electrical cable connection as follows:

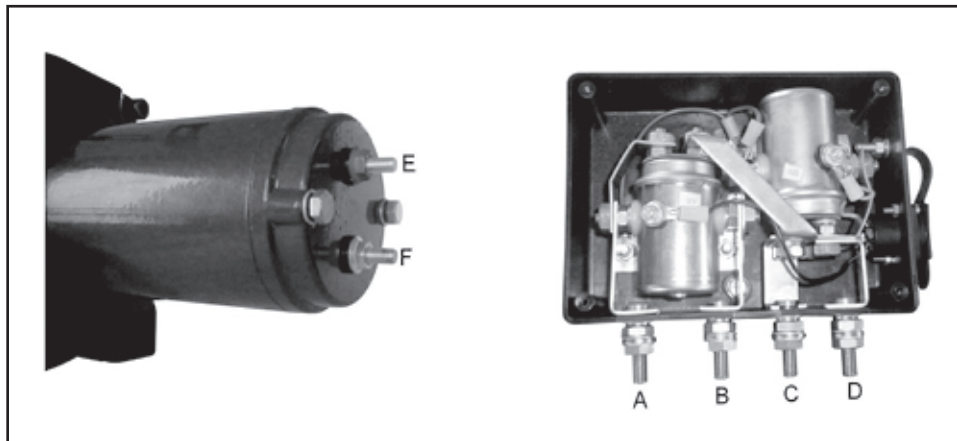

- 1- One terminal of short red cable connecting to the red terminal E of the motor, the other connecting to the terminal A of Control Box. (We have done this before leaving factory.)
- 2- One terminal of short black cable connecting to the black terminal F of the motor, the other connecting to the terminal D of Control Box. (We have done this before leaving factory.)
- 3- Long red cable, one terminal connecting to the red terminal B of the Control Box, the other connecting to positive (+) terminal of battery.
- 4- Long black cable, one terminal connecting to the black terminal C of the Control Box, the other connecting to negative (-) terminal of battery.

OPERATION

SUGGESTION:

- The best way to get acquainted with how your winch operates is to make a few test runs before you actually need to use it. Plan your test in advance. Remember you can hear your winch as well as you can see it operate. Get to recognize the sound of a light steady pull, a heavy pull, and sounds caused by load jerking or shifting. Soon you will gain confidence in operating your winch and its use will become second nature to you.

OPERATION:

- 1- Ensure the vehicle is secure by applying the parking brake or block the wheels.
- 2- Pull out the desired length of the winch wire rope and connect to an anchor point. The winch clutch allows rapid uncoiling of the wire rope for hooking onto the load or anchor point. The shifter tab located on the gear housing of the winch operates the clutch as follows:

To disengage the clutch, move the clutch shifter tab to the "OUT". Wire rope may be free spooled off the drum.

To engage the clutch, move the clutch shifter tab into the "IN" position. The winch is now ready for pulling.

- 3- Recheck all wire rope rigging before proceeding.
- 4- Plug in the winch hand control. It is recommended that the winching operation takes place from the driver's position to ensure safe operation.
- 5- To commence winching operation, start vehicle engine, select transmission in neutral, maintain engine speed at idle.
- 6- Operate the remote control switch to IN or OUT until the vehicle has been retrieved. Regularly check the winch to ensure wire rope is winding onto the drum evenly.
- 7- Any time the control switch is in the neutral or off position, the brake will automatically activate against a load.

▲ NOTE: Carefully read the SAFETY RULES and WINCH OPERATION WARNINGS before operation winch.

MAINTENANCE

- It is highly recommended that the winch be used regularly (once a month). Winch should not be submerged in water. If winch is accidentally submerged, it should be operated within 3 days until motor is warm to the touch. This should drive out any moisture that has entered the motor.

LUBRICATION

- All moving parts in the winch are permanently lubricated with high temperature lithium grease at the time of assembly. Under normal conditions factory lubrication will surface. Lubricate wire rope periodically using light penetrable oil. Inspect broken stands and replace if necessary. If the wire rope becomes worn or damaged, it must be replaced.

WIRE ROPE REPLACEMENT

- Unwind the new wire rope along the ground, to prevent kinking. Remove old wire rope and attach new one. Note the manner the wire rope is connected to cable drum flange.

EXPLODED DIAGRAM

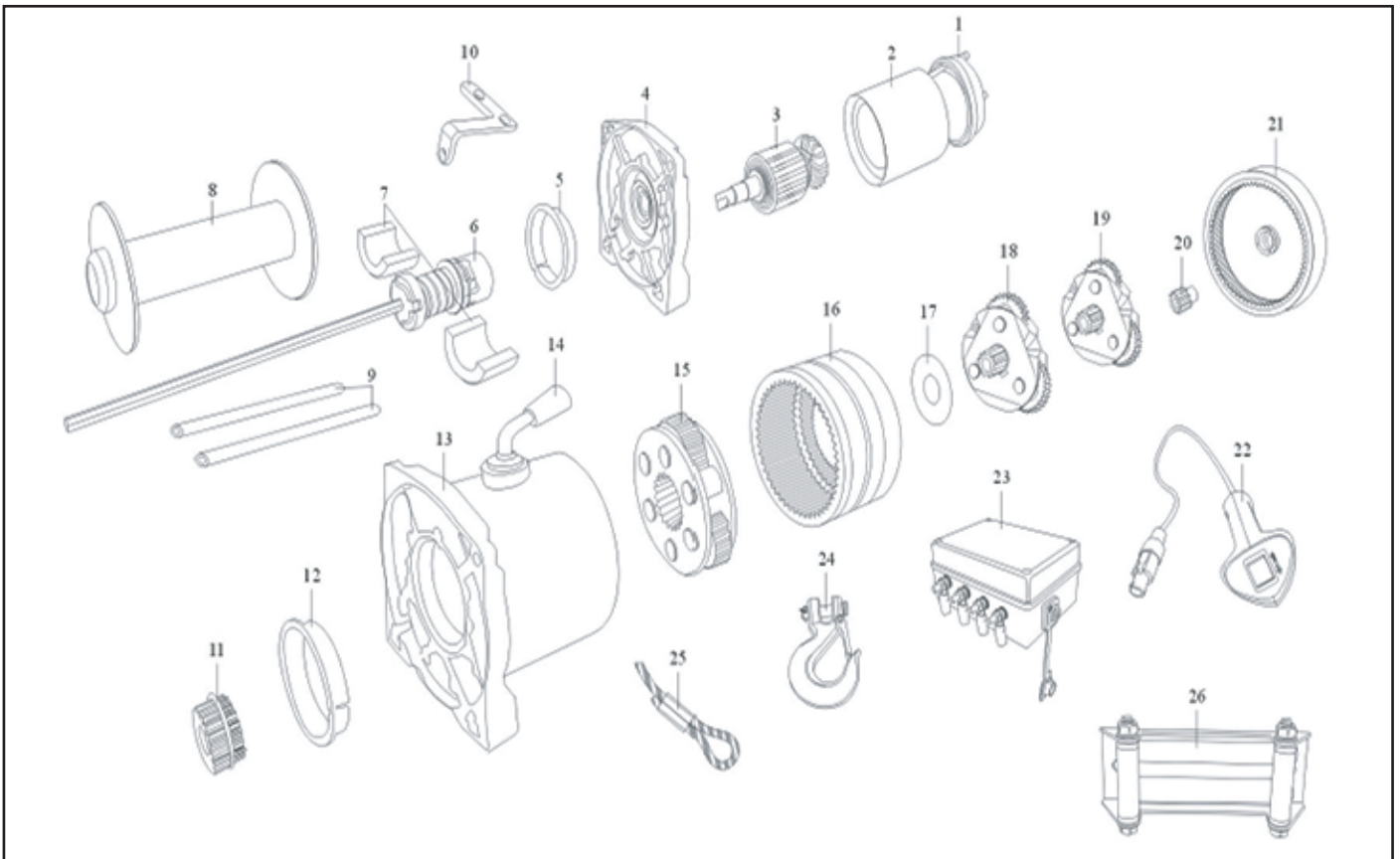

PARTS LIST

No	Description	No	Description
1	Motor cover (Carbon Ass'y inside)	14	Clutch knob
2	Stator	15	Planetary Gear
3	Rotor	16	Inner Gear
4	Motor Base	17	Washer
5	Nylon Bush	18	Planetary Gear
6	Brake	19	Planetary Gear
7	Brake ring	20	Sun Gear
8	Drum	21	Shell
9	Tie Bar	22	Switch Ass'y
10	frame for Solenoid	23	Solenoid Box Ass'y
11	Spline Joint	24	Hook
12	Nylon Bush	25	Wire Rope
13	Supporting Base	26	Roller fairlead