

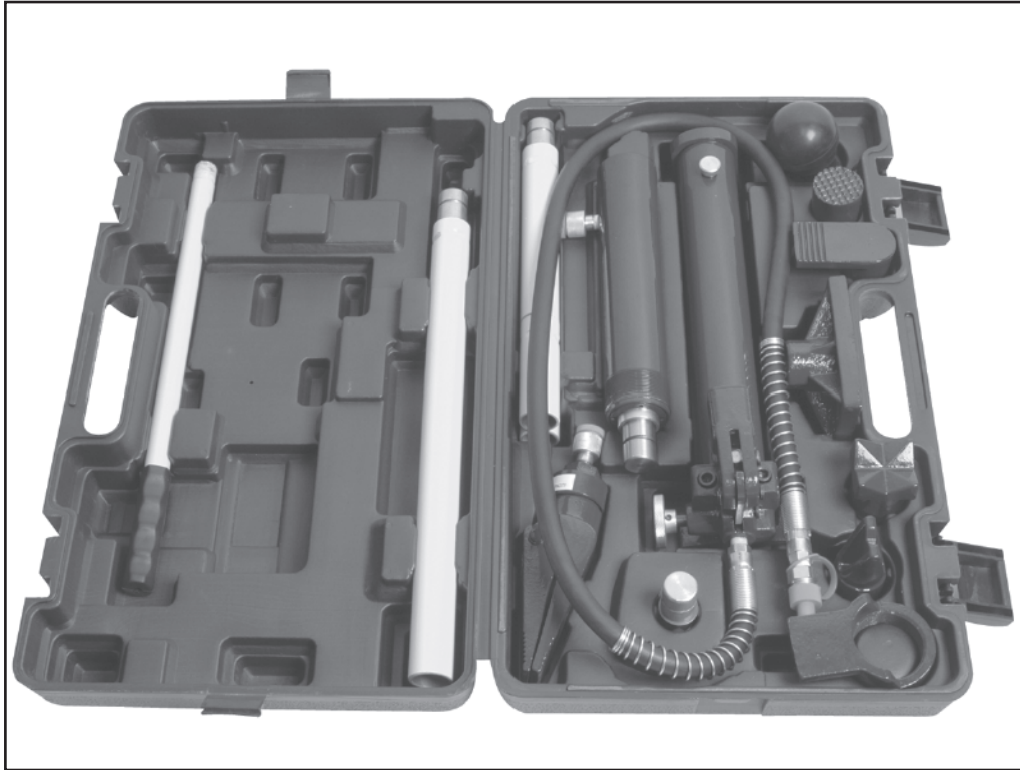

# Assembly & Instruction Manual

**ITEM 3136**

VENDOR: B | SERIES: 1



# 10 TON HYDRAULIC PORTA POWER KIT

THANK YOU FOR BUYING CUMMINS INDUSTRIAL TOOLS  
You can purchase additional items at  
[www.cumminstools.com](http://www.cumminstools.com)

**SAVE THIS MANUAL FOR FUTURE REFERENCE**



Customer Service Postal Address:  
1290 35 Road  
Minden, NE 68959  
Voice: 1-(308) 832-2070  
Fax: 1-(308) 832-2069

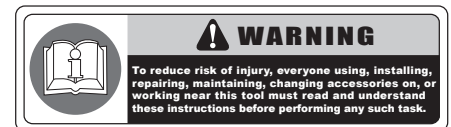

Your new 10 TON HYDRAULIC PORTA POWER KIT has been engineered and manufactured to Cummins Industrial Tools high standards for dependability, ease of operation, and operator safety. Pay close attention to the Rules for Safe Operation, Warnings, and Cautions. If you use your machine properly and only for what it is intended, you will enjoy years of safe, reliable service.

# TABLE OF CONTENTS

■ Introduction .....	1
■ General Safety Rules .....	2
■ Specific Safety Rules .....	3
■ Product Specifications .....	3
■ Product Overview .....	4
■ Unpacking .....	5
■ Packing List .....	5
■ Assembly .....	5-6
■ Operation .....	7-8
■ Maintenance .....	8-9
■ Troubleshooting .....	9
■ Assembly Diagram & Parts List .....	10-12

## INTRODUCTION

- THIS PRODUCT has many features for making the use of this product more pleasant and enjoyable. Safety, performance, and dependability have been given top priority in the design of this product making it easy to maintain and operate.

**▲ WARNING:** Do not attempt to use this product until you thoroughly read and completely understand the operator's manual. Pay close attention to the safety rules, including Dangers, Warnings, and Cautions. If you use your product properly and only as intended, you will enjoy years of safe, reliable service.

- ▲ !** Look for this symbol to point out important safety precautions. It means attention!!! Your safety is involved.



**▲ WARNING:** The operation of any tool can result in foreign objects being thrown into your eyes, which can result in severe eye damage. Before beginning operation, always wear safety goggles or safety glasses with side shields and a full face shield when needed. We recommend Wide Vision Safety Mask for use over eyeglasses or standard safety glasses with side shields. Always wear eye protection which is marked to comply with ANSI Z87.1.

# GENERAL SAFETY RULES

**⚠ WARNING:** When using tool, basic safety precautions should always be followed to reduce the risk of personal injury and damage to equipment. Read all instructions before using the tool!

- **Work area conditions.** Cluttered areas invite injuries.
- **Additional work area conditions.** Do not use machines or power tools in damp or wet locations. Do not expose to rain. Keep work area well lighted.
- **Keep children away.** Children must never be allowed in the work area. Do not let them handle machines, tools or extension cords.
- **Store idle equipment.** When not in use, tools must be stored in a dry location to inhibit rust. Always lock up tools and keep out of reach of children.
- **Use the right tool for the job.** Do not attempt to force a small tool or attachment to do the work of a larger industrial tool. There are certain applications for which this tool was designed. It will do the job better and more safely at the rate for which it was intended. Do not modify this tool and do not use this tool for a purpose for which it was not intended.
- **Dress properly.** Do not wear loose clothing or jewelry as they can be caught in moving parts. Protective, electrically non-conductive clothes and non-skid footwear are recommended when working. Wear restrictive hair covering to contain long hair.
- **Use eye protection.** Always wear ANSI approved impact safety glasses underneath a full face shield during use. Also, wear heavy duty work gloves.
- **Do not overreach.** Keep proper footing and balance at all times. Do not reach over or across running machines.
- **Maintain tools with care.** Keep tools sharp and clean for better and safer performance. Follow instructions for lubricating and changing accessories. The handles must be kept clean, dry, and free from oil and grease at all times.
- **Remove adjusting keys and wrenches.** Check that keys and adjusting wrenches are removed from the tool or machine work surface before starting work.
- **Stay alert.** Watch what you are doing, use common sense. Do not operate any tool when you are tired.
- **Check for damaged parts.** Before using any tool, any part that appears damaged should be carefully checked to determine that it will operate properly and perform its intended function. Any part that is damaged should be replaced.
- **Replacement parts and accessories.** When servicing, use only identical replacement parts. Use of any other parts will void the warranty. Only use accessories intended for use with this tool. Approved accessories are available from Cummins Industrial Tools.
- **Do not operate tools if under the influence of alcohol or drugs.** Read warning labels on prescriptions to determine if your judgment or reflexes are impaired while taking drugs. If there is any doubt, do not operate the tool.

**⚠ WARNING:** The warnings, cautions, and instructions discussed in this instruction manual can not cover all possible conditions and situations that may occur. It must be understood by the operator that common sense and caution are factors which can not be built into this product, but must be supplied by the operator.

## SPECIFIC SAFETY RULES

- **KEEP COUPLER VALVES PROTECTED WHEN NOT IN USE.** Dust caps are included for all Coupler Valves and should be screwed in when not in use to keep equipment clean.
- **BEFORE WORKING ON A VEHICLE ALWAYS SET THE PARKING BRAKE AND BLOCK THE TIRES.** Never attempt a repair while the engine is running or the vehicle is moving.
- **DO NOT OVER EXTEND THE HYDRAULIC ARM.** Over extending the Spreader Ram may force the plunger out of the top of the ram, causing damage.
- **AVOID OFF-CENTER LOADS.** If the **Pump Unit** seems unusually hard to pump, immediately stop the operation. Adjust the Portable Puller Set to eliminate or diminish an off-center load.
- **PROTECT THE HOSE.** Do not drop heavy objects on the Hose. Avoid sharp kinks in the hose. Make sure there is proper clearance to avoid damage to the hose and coupler.
- **KEEP THE HYDRAULIC UNIT PROPERLY FILLED WITH OIL.** Collapse the Hydraulic Spreader Ram if it is connected to the Pump Unit. Place the Pump Unit in the upright position. Remove the filler plug and add hydraulic oil until it is level with the full mark on the stem of the hydraulic unit.

## PRODUCT SPECIFICATIONS

- Kit contains the heavy duty hydraulic equipment you need for lifting, pushing, pulling, bending, straightening and spreading
- **Pump Rated Capacity** 10 Tons
- **Ram Rated Capacity** 10 Tons @ 100%
- **Ram Capacity W/Extensions** 5 Tons @ 50%
- **Ram Stroke** 5-1/8"
- **Ram Min. Height** 12-5/8"
- **Oil Being Filled** 500 g
- **Hydraulic Spreader Capacity** 1/2 Ton
- **Pump Output Pressure** 63 MPa

# PRODUCT OVERVIEW

- The 10 Ton Hydraulic Porta Power Kit is designed for bending frames and repairing dents in vehicle body panels. **In most cases the kit will only be able to return vehicle body parts to their approximate original position.** Additional work may be required to completely repair the vehicle part.
- Included are two attachments for the Pump Unit. The Hydraulic Ram is used in larger spaces where greater force is needed and where there is sufficient room. The Spreader Wedge is used in tighter spaces where the Hydraulic Spreader Ram will not fit.
- The Hydraulic Ram and the Spreader Wedge both require a solid, non-movable base directly across from the damaged area and in line with the direction the damaged area needs to be bent.

## The Hydraulic Ram Attachments

- The Hydraulic Ram comes with several different attachments that, depending on the damage, may be used to achieve the desired results.
  - A The **Extension Bars** plug in together in different combinations to reach desired lengths.
  - B The **Serrated Cap** is typically used on the pushing end in frame repair. The Serrated Cap may be plugged into either end of the Hydraulic Ram or Extension Bars.
  - C The **Rubber Head** is typically used for popping dents out of sheet metal such as doors or body panels. The Rubber Head may be plugged into either end of the Hydraulic Ram or Extension Bars.
  - D The **Flat Base** is typically used on the stationary side to spread out the force of the Hydraulic Ram. The Flat Base may be plugged into either end of the Hydraulic Ram or Extension Bars.
  - E The **Spreader Wedge** is used when the Hydraulic Ram is too long to fit between the stationary side and the damaged area. The Spreader Wedge screws into the Pump Unit.
  - F The **90 Degree V Base** is used to offset the force of the Hydraulic Ram when there is not a straight line between the stationary side and the damaged side. The 90 Degree V Base may be attached to either end of the Hydraulic Ram or Extension Bars.
  - G The **Wedge Head** is used to repair small dents and areas located in angles and tight spaces. The Wedge Head attaches to the Hydraulic Ram or Extension Bars.
  - H The **Male Connector** is used with the Extension Bars and other attachments. The Male Connector plugs into the female end of the Hydraulic Ram.
  - I The **Spreader Plunge Toe** and **Spreader Ram Toe** may be attached to either end of the Hydraulic Ram or Extension Bars.
  - J As a rule of thumb, when positioning the Hydraulic Ram use a smaller attachment on the side that is to be bent (as opposed to the stationary side). If the stationary side is in danger of being bent or damaged, place a block of wood or other material behind the Flat Base for protection and to spread the Stroke Ram pressure over a greater area.

# UNPACKING

## INSTRUCTIONS

### When unpacking the tool:

- Carefully remove the tool and accessories from the box.
- Make sure that all items listed in the packing list are included.
- Inspect the tool carefully to make sure no breakage or damage occurred during shipping.
- Do not discard the packing material until you have carefully inspected and satisfactorily operated the tool.

**⚠ WARNING:** If any part are missing do not operate the tool until the missing parts are replaced. Failure to do so could result in possible serious personal injury.

# PACKING LIST

### PUMP UNIT

NO	DESCRIPTION	QTY
1	Pump Unit	1
2	Hydraulic Ram	1
3	Hose	1
4	19-1/4" Extension Bar	1
5	13-1/4" Extension Bar	1
6	9-1/2" Extension Bar	1
7	5-1/2" Extension Bar	1
8	Serrated Cap	1
9	Spreader Wedge	1
10	Rubber Head	1
11	Wedge Head	1
12	90° V Base	1
13	Spreader Plunge Toe	1
14	Spreader Ram Toe	1
15	Male Connector	1
16	Flat Base	1
17	Pump Handle	1
18	Storage Case	1

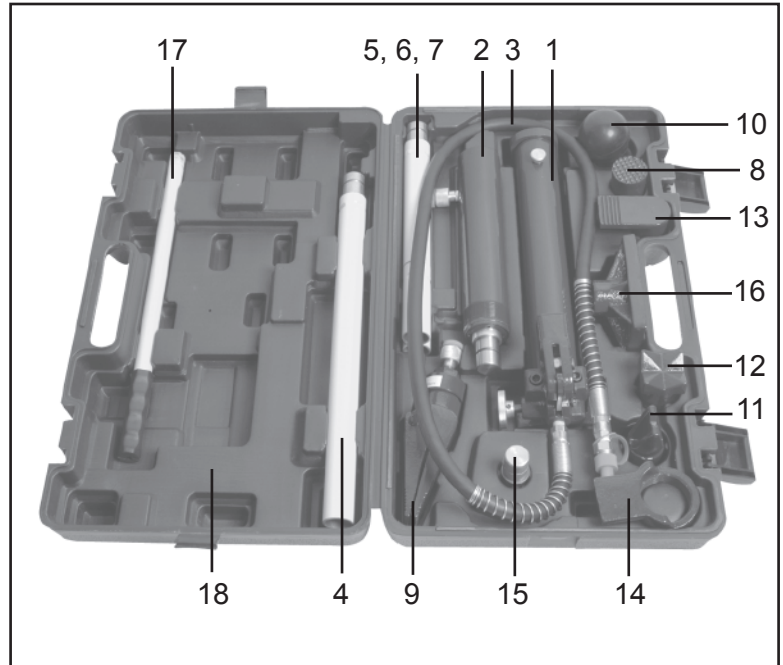

# ASSEMBLY

### To assemble Hydraulic Ram, Pump Unit, and Attachments

- 1- Unscrew and save the End Plugs located on the ends of the Hose and Hydraulic Ram.
- 2- Securely screw the Hose into the Hydraulic Ram. (See Figure A.)

# ASSEMBLY

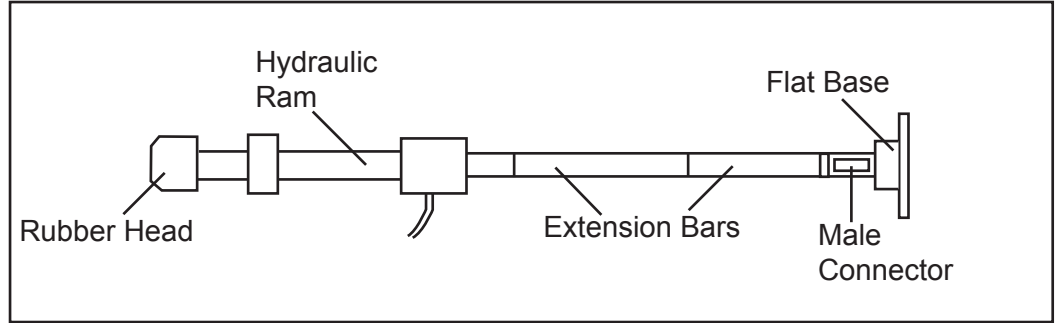

Figure A

- 3- Insert the Pump Handle into the receptacle located at the top of the Pump Unit.
- 4- To attach the Rubber Head, the Extension Bars, the Male Connector, and the Flat Base to the Hydraulic Ram, see Figure A.
- 5- To attach the Spreader Wedge to the Pump Unit, see Figure B.

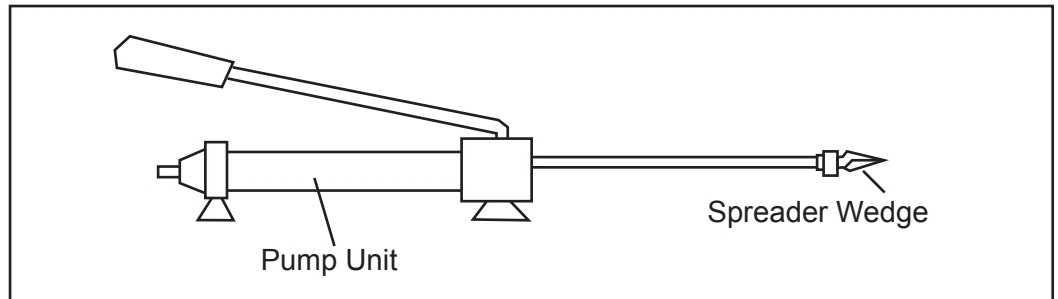

Figure B

- 6- For other attachment combinations see Figure C.

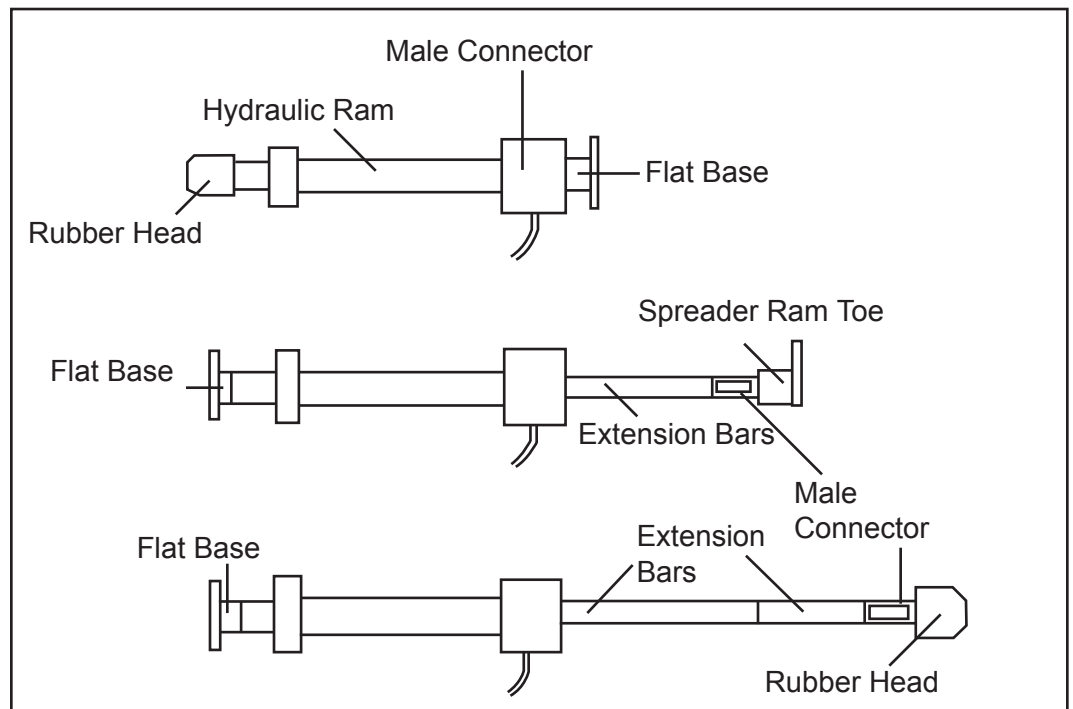

Figure C

# OPERATION

## To Operate the Hydraulic Pump Unit

- 1- Position the Pump Unit on a stable, flat and level surface close to the damaged area.
- 2- Firmly close the Release Valve Stem by turning it clockwise and pump the Pump Handle to apply pressure.
- 3- Turn the Release Valve Stem counterclockwise to release the pressure.
- 4- The Pump Unit may be positioned horizontally or vertically. When using the Hydraulic Unit in a vertical position, always keep the Hose end of the Hydraulic Unit downward.

## To Repair Frame Damage

- 1- Determine which direction the frame needs to be bent.
- 2- Remove any obstructions that could be damaged or are in the way.
- 3- Connect the Flat Base to the stationary side of the Hydraulic Ram and connect the appropriate attachment to the pushing end of the Stroke Ram.
- 4- Position the Hydraulic Ram so that the Flat Base is resting against a frame member opposite the damaged area. It must also be in line with the direction in which the damaged area needs to be pushed.
- 5- Aim the pushing end towards the area that needs to be repaired and slowly apply pressure with the Pump Unit.
- 6- Once contact on either end has been made, step away as far as possible and continued to slowly apply pressure to the damaged area until the desired bend has been made.

**⚠ CAUTION:** Keep hands away from contact areas and tight spaces. The Portable Puller Set may slip and cause injury.

- 7- When the damaged area has been bent to the desired position, slowly turn the Release Valve Stem on the Pump Unit in a counterclockwise direction to release the hydraulic pressure and remove the Hydraulic Ram.

## To Repair Body Damage

- 1- Determine which direction the body panel should be moved.
- 2- Remove any obstructions that could be damaged or are in the way.
- 3- Connect the appropriate attachments to the Hydraulic Ram.  
**Note:** When repairing larger body panel dents such as a dented door, fender or quarter-panel, the proper pushing attachment will be the Rubber Head.
- 4- Position the Hydraulic Ram so that the Flat Base is resting against a frame or a sturdy body part opposite the damaged area. It must also be in line with the direction in which the damaged area needs to be pushed. Make sure the body part is stronger than the area to be bent or it may be damaged. A block of wood or a towel may be used to protect the body part.
- 5- Aim the pushing end towards the area that needs to be repaired and slowly apply pressure with the Pump Unit.
- 6- Once contact on either end has been made, step away as far as possible and continued to slowly apply pressure to the damaged area until the desired bend has been made.

## OPERATION

**⚠ CAUTION:** Keep hands away from contact areas and tight spaces. The Portable Puller Set may slip and cause injury.

- 7- When the damaged area has been bent to the desired position, slowly turn the Release Valve Stem on the Pump Unit in a counterclockwise direction to release the hydraulic pressure and remove the Hydraulic Ram.

### To Use the Spreader Wedge

- 1- Determine which direction the frame needs to be bent.
- 2- Remove any obstructions that could be damaged or are in the way.
- 3- Place Spreader Wedge so that the hinged arm is resting against the part to be moved and the stationary arm is resting against a non-movable base. Hold the Spreader Ram in position and apply the Pump Unit pressure.
- 4- Once contact on either end has been made, step away as far as possible and continued to slowly apply pressure to the damaged area until the desired bend has been made.

**⚠ CAUTION:** Keep hands away from contact areas and tight spaces. The Portable Puller Set may slip and cause injury.

- 5- When the damaged area has been bent to the desired position, slowly turn the Release Valve Stem on the Pump Unit in a counterclockwise direction to release the hydraulic pressure and remove the Hydraulic Ram.

## MAINTENANCE

- 1- Determine which direction the frame needs to be bent.
- 2- Before each use, examine the general condition of the tool. Inspect the tool and its accessories for damage. Check for loose bolts, misalignment, binding of moving parts, broken parts and any other condition that may affect its safe operation. Do not use a damaged tool or its damaged accessories.
- 3- When the Portable Puller Set is not in use, the Pump Unit should be stored with the Release Valve Stem open.
- 4- After extensive use, the hydraulic oil supply should be replaced to ensure longer equipment life.
- 5- To check the oil level:
  - a. Set Pump Unit flat on a level surface.
  - b. Remove the Screw with its attached dipstick.
  - c. The oil level should be near the bottom of the opening. If required, add high grade hydraulic oil.
  - d. Replace the Screw.

# MAINTENANCE

- 6-** To bleed the pump:
- a. Check the oil level and fill if necessary, following procedures for checking the oil level.
  - b. Firmly close the Release Valve Stem by turning it clockwise.
  - c. To bleed the pump, press the tip of the Coupling against a hard surface and pump the pump handle.
  - d. Continue pumping until the hydraulic fluid coming out from the end of the coupler tip is free of air bubbles.
  - e. Recheck the oil level and add oil if necessary.
  - f. Turn the Release Valve Stem counterclockwise to release the pressure in the pump and hose.

# TROUBLESHOOTING

Symptom	Possible Causes	Corrective Action
Ram won't lift load.	Release valve not tightly closed. Overload condition Air trapped in system.	Firmly close release valve. Remedy overload condition Purge away air from system.
Ram won't maintain hold.	Release valve not tightly close. Hydraulic unit malfunction.	Firmly close release valve. Replace ram and / or pump.
Ram won't lower after unloading.	Reservoir overfilled Linkage binding.	Drain oil to proper level. Clean and lubricate moving parts.
Ram won't extend to full stroke.	Oil level low.	Add hydraulic oil.
Poor performance.	Oil level low. Air trapped in system.	Add hydraulic oil. Purge away air from system.

### PLEASE READ THE FOLLOWING CAREFULLY

THE MANUFACTURER AND/OR DISTRIBUTOR HAS PROVIDED THE PARTS LIST AND ASSEMBLY DIAGRAM IN THIS MANUAL AS A REFERENCE TOOL ONLY. NEITHER THE MANUFACTURER NOR THE DISTRIBUTOR MAKES ANY REPRESENTATION OR WARRANTY OF ANY KIND TO THE BUYER THAT HE OR SHE IS QUALIFIED TO MAKE ANY REPAIR TO THE PRODUCT, OR THE HE OR SHE IS QUALIFIED TO REPLACE ANY PARTS OF THE PRODUCT. IN FACT, THE MANUFACTURER AND/OR DISTRIBUTOR EXPRESSLY STATES THAT ALL REPAIRS AND PARTS REPLACEMENTS SHOULD BE UNDERTAKEN BY CERTIFIED AND LICENSED TECHNICIANS, AND NOT BY THE BUYER. THE BUYER ASSUMES ALL RISK AND LIABILITY ARISING OUT OF HIS OR HER REPAIRS TO THE ORIGINAL PRODUCT OR REPLACEMENT PARTS THERETO, OR ARISING OUT OF HIS OR HER INSTALLATION OF REPLACEMENT PARTS THERETO.

# ASSEMBLY DIAGRAM & PARTS LIST

## SET A: 1/2 TON RAM

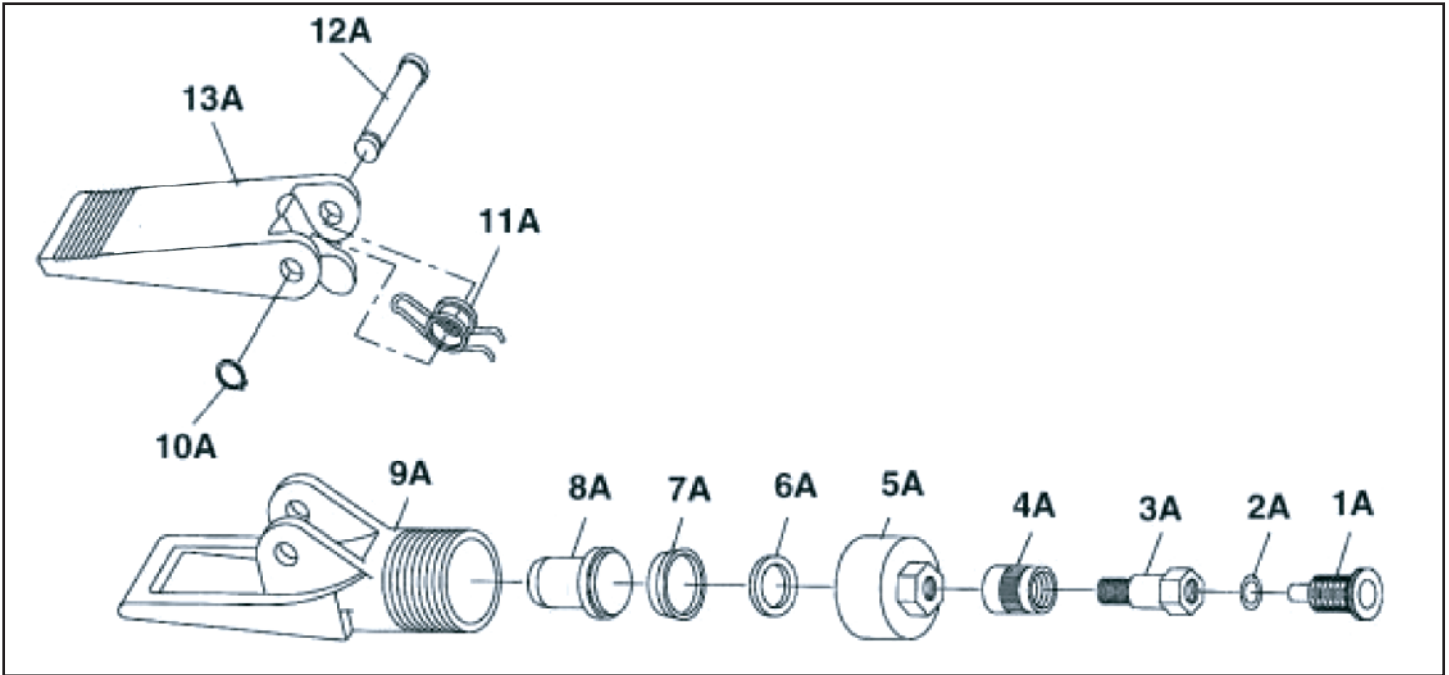

NO	DESCRIPTION	NO	DESCRIPTION
1A	Dust Cap	8A	Piston
2A	Bolt "O" Ring	9A	Lower Duck Bill
3A	Coupling Bolt	10A	Circle Clip
4A	Coupling Ring	11A	Spring
5A	End Cap	12A	Pivoting Pin
6A	Washer	13A	Upper Duck Bill
7A	Cup Seal		

**Note:** Some parts are listed and shown for illustration purposes only, and are not available individually as replacement parts.

# ASSEMBLY DIAGRAM & PARTS LIST

## SET B: 10-TON, 5" STROKE RAM

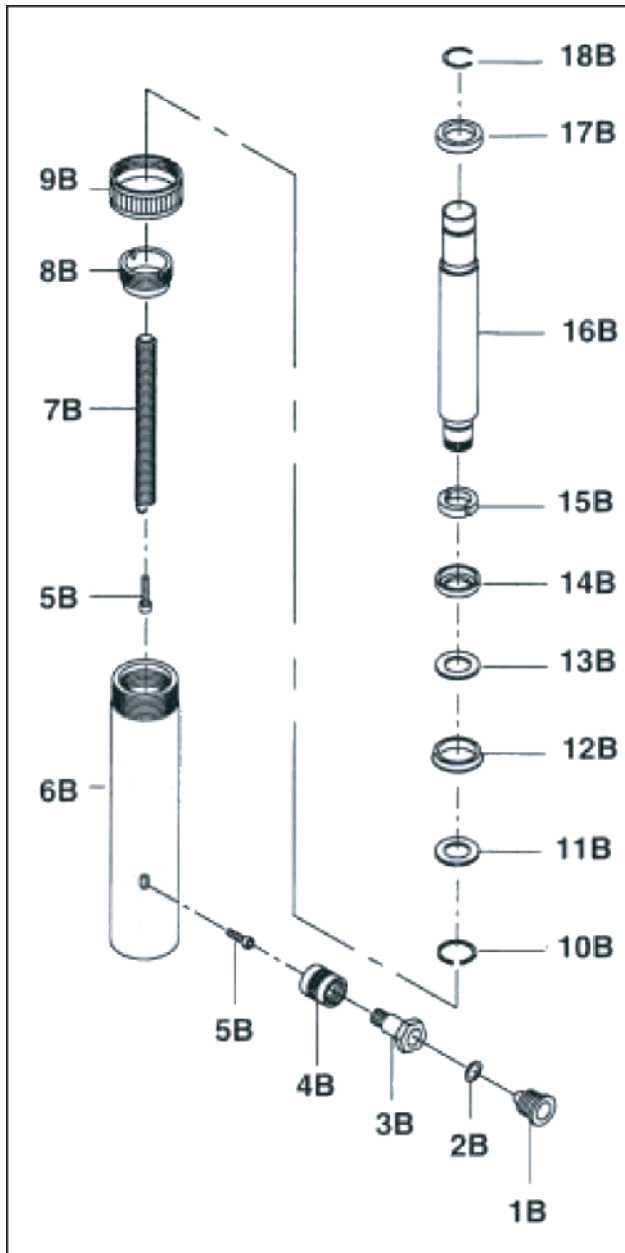

NO	DESCRIPTION
1B	Dust Cap
2B	Bolt "O" Ring
3B	Coupling Bolt
4B	Coupling Ring
5B	Screw
6B	Cylinder
7B	Spring
8B	Ring
9B	Protector Cap
10B	Circle Cap
11B	Washer
12B	"U" Seal
13B	Backup Ring
14B	Bushing
15B	Bearing
16B	Ram
17B	Washer
18B	Snap Ring "C"

**Note:** Some parts are listed and shown for illustration purposes only, and are not available individually as replacement parts.

# ASSEMBLY DIAGRAM & PARTS LIST

## SET C: 10-TON HYDRAULIC PUMP

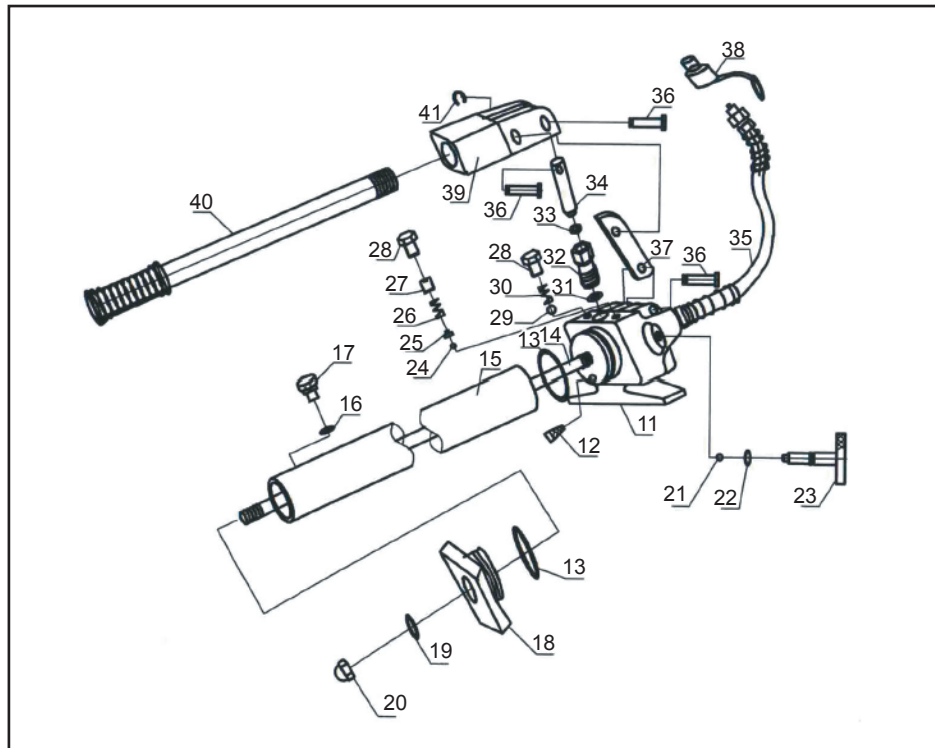

No	Description	Qty
1	Blow Box	1
2	Tube	1
3	Base	1
4	Spreader Ram Toe	1
5	Plate Head	1
6	Wedge Head	1
7	Square Head	1
8	Movable Connection	1
9	Serrated Saddle	1
10	Rubber Head	1
11	Valve Block	1
12	Oil Filter	1
13	O-Ring	2
14	Tie Rod	1
15	Reservoir	1
16	Ring	1
17	Breath Valve	1
18	Pump Foot	1
19	Ring	1
20	Screw	1
21	Ball	1

No	Description	Qty
22	Ring	1
23	Release Valve	1
24	Ball	1
25	Bushing	1
26	Spring	1
27	Screw	1
28	Screw	2
29	Ball	1
30	Spring	1
31	Seal	1
32	Piston Block	1
33	Y-Ring	1
34	Piston	1
35	Hydraulic Hose	1
36	Pin	3
37	Connector	1
38	Dust Proof Cover	1
39	Handle socket	1
40	Handle	1
41	Retaining Ring	3