



# Assembly & Instruction Manual

**ITEM 3122**

VENDOR: A SERIES: 1



# 12 TON HYDRAULIC JACK

THANK YOU FOR BUYING CUMMINS INDUSTRIAL TOOLS  
You can purchase additional items at  
[www.cumminstools.com](http://www.cumminstools.com)

**SAVE THIS MANUAL FOR FUTURE REFERENCE**



Customer Service Postal Address:  
1290 35 Road  
Minden, NE 68959  
Voice: 1-(308) 832-2070  
Fax: 1-(308) 832-2069

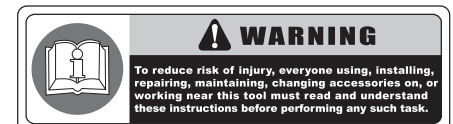

Your new 12 Ton Hydraulic Jack has been engineered and manufactured to Cummins Industrial Tools high standards for dependability, ease of operation, and operator safety. Pay close attention to the Rules for Safe Operation, Warnings, and Cautions. If you use your machine properly and only for what it is intended, you will enjoy years of safe, reliable service.

# PRODUCT SPECIFICATIONS

## Specifications

- **Weight Capacity** 12 Tons
- **Minimum Height** 8-1/2"
- **Maximum Height** 17" (with Elevating Screw Extended)

## Specific Safety Rules

- **Do not exceed the maximum lift capacity for the Jack:**  
12 Tons maximum lift capacity. Overloading the jack could cause serious personal injury and / or property damage.
- **The Jack is designed for intermittent use only.**  
Do not use the Jack to support a vehicle over extended periods of time. The duration of the lifting job should be kept as short as possible. Always use jack stands to support a vehicle over an extended period of time.
- **Maintain labels and nameplates on the Jack.**  
These carry important information. If unreadable or missing, contact Cummins Industrial Tools for a replacement.
- **Prior to using the Jack, make sure to read and understand all warning, safety precautions, and instructions as outlined in the manufacture's instruction manual for the vehicle (or object) you will lift.**
- **When lifting only one wheel, make sure to support the load immediately with one jack stand (not included) placed under the side of the vehicle being lifted.**  
Align the saddle of the jack stand directly under the vehicle's seam or recommended lifting point.
- **When lifting the entire front end or rear end of a vehicle, make sure to support the load immediately with two jack stands.**  
Align the saddles of the jack stands directly under the vehicle's frame or recommended lifting points. Also make sure the jack stands are adjusted at the same height.
- **Make sure the Jack is used only on a dry, oil / grease free, flat, level, solid surface capable of supporting the weight of the vehicle being lifted and any additional tools and equipment.**
- **Do not work under the vehicle without properly supporting the vehicle with jack stands.**  
Make sure the load and jack stands are stable before getting under a vehicle.
- **Use the Jack only on vehicles whose frames have lifting points (on its seam or frame) capable of aligning with the Elevating Screw of the Jack.**  
Make sure the load and jack stands are stable before getting under a vehicle.

# PRODUCT SPECIFICATIONS

- **Avoid dangerous oncoming traffic.** Always use the Bottle Jack as far away for the roadside as possible.
- **Do not use the Bottle Jack with the vehicle's engine running.** Make sure to place the vehicle's transmission in "Park" (if automatic) or "1st Gear" (if manual). Then set emergency brake, and block the tires opposite the tire being lifted.
- **Industrial applications must follow OSHA requirements.**
- **Always keep hands, fingers, and feet away from all moving parts of the Jack when applying or releasing a load.** Remain clear of the vehicle being raised or lowered. People and animals should be kept at a safe distance when using th jack.
- **Use extreme caution when applying or releasing a load.** Never allow the load to suddenly release. Slowly and carefully apply and release the load.
- Do not allow anyone in the vehicle while using the Jack. Keep all bystanders a safe distance away form the vehicle.
- Never leave the Jack unattended when the Jack is under a load.
- Never support both ends of the vehicle at eh same time.
- Before lowering the Jack, make sure tool trays, jack stands, and all other tools and equipment are removed from under the vehicle.
- Do not stand on the Jack as it may tip, causing personal injury.
- If changing a damaged tire, make it easier to remove the lug nuts by slightly loosening the lug nuts before raising the tire of the ground.
- These jacks are not to be used for aircraft purposes. Never modify the Jack in an attempt to use it for a purpose it was not designed for.
- The warnings, precautions, and instructions discussed in his manal cannot cover all possible conditions and situatiions that may occur. The operator use understand that common sense and cautions are factors which cannot be built into this product, but must be supplied by the operator.

# OPERATING INSTRUCTIONS

**IMPORTANT!** Prior to its first use, make sure to check for proper hydraulic oil level in the bottle jack. Then thoroughly test the bottle jack for proper operating prior to its actual use. If the bottle jack appears not to be working properly, it may be necessary to purge its hydraulic system of excess air.

- To do so, remove the Oil Filler Plug (33). Assemble the complete Handle Assembly (34). Insert the lower portion of the Handle Assembly onto the Valve Release Screw (4). Turn the Handle Assembly clockwise to close the Valve Release Screw. Insert the Handle Assembly into the Plunge / Fulcrum Assembly (17). Apply pressure to the Elevating Screw (24), and pump the Handle Assembly slowly several times. The trapped air is pressurized and will be audible when released in this manner. Once purged of air check Oil Fill Hole and, if necessary, top off the Oil Fill Hole with hydraulic oil. Then, replace the Oil Fill Plug. Turn the Handle Assembly counterclockwise slowly to completely lower the jack. Test the jack several times for proper operation before attempting to lift a load.
- If, after purging, the jack still does not appear to be working properly, do not use the jack until it has been repaired by a qualified service technician.
- **CAUTION! Make sure the vehicle is parked on a flat, level, solid, ground surface safely away from oncoming traffic.** Turn off the vehicle's engine. Place the vehicle's transmission in "PARK" (if automatic) or in its lowest gear (if manual). Set the vehicle's emergency brake. Then, block the wheels that are not being lifted.

Figure A

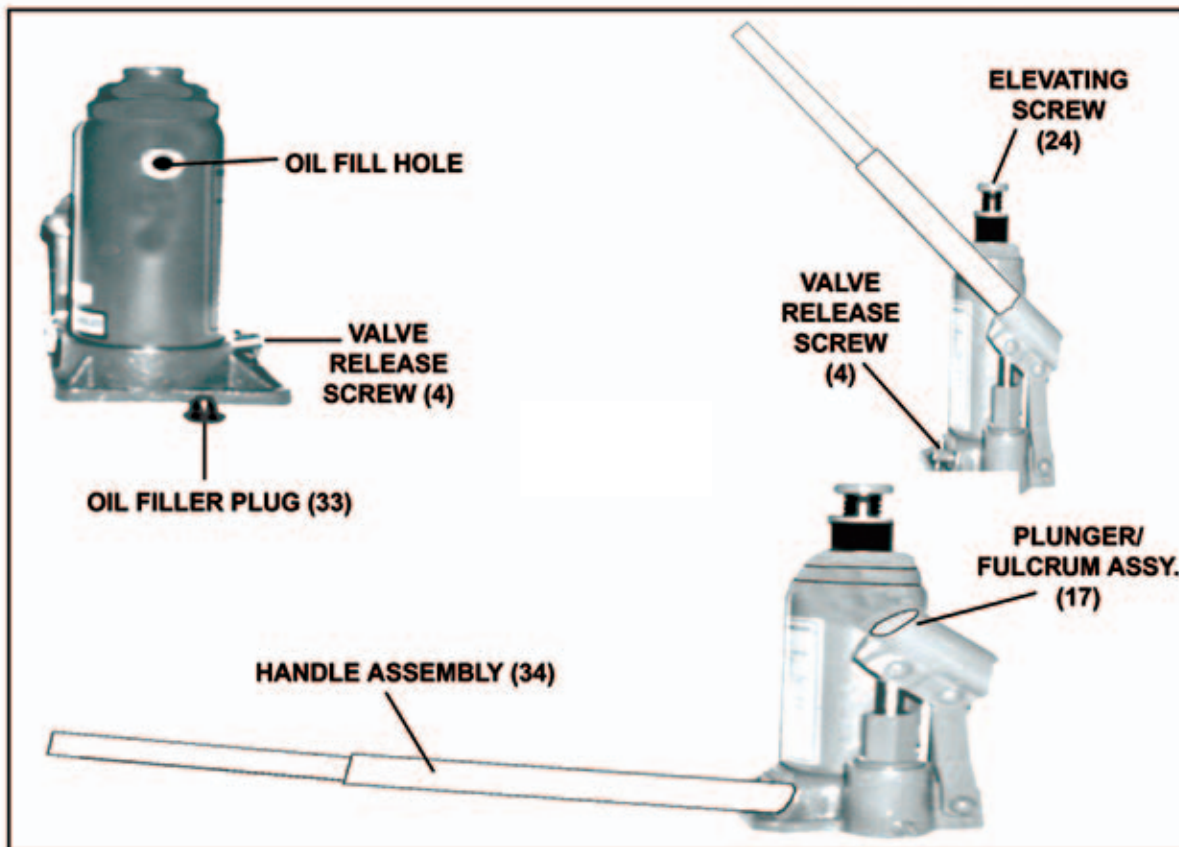

# OPERATING INSTRUCTIONS

- Check to make sure the jack is fully lowered. If not, assemble the Handle Assembly (34). Insert the lower portion of the Handle Assembly into the Valve Release Screw (4), and turn the Handle Assembly counterclockwise to lower the jack. Once the jack is fully lowered, turn the Handle Assembly firmly clockwise to close the Valve Release Screw. (See Figure A.)
- Carefully position the Elevating Screw (24) of the jack under the vehicle manufacture's recommended lifting point. If necessary, adjust the height of the Elevating Screw by turning it clockwise or counterclockwise. (See vehicle manufacture's owner's manual for location of seam lifting point when lifting only one wheel and frame lifting points when lifting the entire front or rear end of the vehicle.) (see Figure A.)
- Pump the Handle Assembly (34) until the top of the jack's Elevating Screw (24) has nearly reached the vehicle lifting point. NOTE: the jack should be positioned at 90 degrees to the vehicle's lifting point to ensure the jack's Elevating Screw and vehicle lifting point are in alignment. If not, remove and reposition the jack before lifting the vehicle.
- To lift the vehicle, pump the Handle Assembly (34) of the jack. Use smooth, full strokes for best result. (See Figure A.)
- Once the vehicle is raised, slide a jack stand (not included) to the proper lifting point referred to in the vehicle owner's manual. If using two jack stands, make sure they are on the same point on each side of the vehicle.
- Center the vehicle's lifting point(s) on the saddle of the jack stand(s). pull up on the saddle of the jack until it is just below the contact points on the vehicle. Make sure to lock the saddle in position. NOTE: if using two jack stands make sure they are at the same height.
- Slowly turn the Handle Assembly (34) counterclockwise to open the Valve Release Screw (4) and lower the vehicle onto saddle(s) of the jack stand(s). Then, turn the Upper/Lower Handle Assembly firmly clockwise to close the Valve Release Screw. (See Figure A.)
- While standing safely aside, gently rock the vehicle to determine if it is stable on the jack stand(s). if it is not, raise the vehicle, and re-position the jack stand(s).
- When the repair work to the vehicle is complete, make sure to remove all tools, old vehicle parts, etc. from under the vehicle.
- Lower the bottle jack completely. Then, store the jack in a safe, dry location out of reach of children and other unauthorized people.

**CAUTION!** When performing this procedure be prepared and stand clear of the vehicle, as the vehicle can fall off the jack stand(s) causing personal injury and/or property damage.

## INSPECTION, MAINTENANCE, AND CLEANING

- **Before each use**, inspect the general condition of the bottle jack. Check for broken, cracked, or bent parts, loose or missing parts, and any condition that may affect the proper operation of the product. If a problem occurs, have the problem corrected before further use. **Do not use damaged equipment.**
- **Before each use, make sure to thoroughly test the bottle jack for proper operation prior to its actual use. If the bottle jack appears not to be working properly, it may be necessary to purge its hydraulic system of excess air.** To do so, remove the Oil Filler Plug (33). Assemble the complete Handle Assembly (34). Insert the lower portion of the Handle Assembly onto the Valve Release Screw (4). Turn the Handle Assembly clockwise to close the Valve Release Screw. Insert the Handle Assembly into the Plunge/fulcrum Assembly (17). Apply pressure to the Elevating Screw (24), and pump the Handle Assembly slowly several times. The trapped air is pressurized and will be audible when released in this manner. Once purged of air check the Oil Fill Hole and if necessary, top off the Oil Fill Hole with hydraulic oil. Then, replace the Oil Filler Plug. Turn the Handle Assembly counterclockwise slowly to completely lower the jack. Test the jack several times for proper operation before attempting to lift a load. **If, after purging the jack still does not appear to be working properly, do not use the jack until it has been repaired by a qualified service technician. (See Figure A.)**
- **Change the hydraulic oil at least once every three years.** To do so, with the bottle jack fully lowered, remove the Oil Filler Plug (33) on the side of the Housing (22). Tip the bottle jack to allow the old hydraulic oil to drain out of the Housing completely, and dispose of the old hydraulic oil in accordance with local regulations. With the bottle jack upright, completely fill the Housing with a high quality hydraulic oil (not included) until the oil just begins to run out of the Oil Fill Hole. Then, re-install the Oil Filler Plug. (See Figure A.)
- **When cleaning**, use a clean cloth with a detergent or mild solvent. Then, store the bottle jack in a safe, dry location out of reach of children and other non-authorized people. Then, re-install the Oil Filler Plug. (See Figure A.)
- **CAUTION!** All maintenance, service, or repairs not listed in this manual are only to be attempted by a qualified service technician.

### PLEASE READ THE FOLLOWING CAREFULLY

THE MANUFACTURER AND/OR DISTRIBUTOR HAS PROVIDED THE PARTS LIST AND ASSEMBLY DIAGRAM IN THIS MANUAL AS A REFERENCE TOOL ONLY. NEITHER THE MANUFACTURER NOR DISTRIBUTOR MAKES ANY REFERENCE OR WARRANTY OF ANY KIND TO THE BUYER THAT HE OR SHE IS QUALIFIED TO MAKE ANY REPAIRS TO THE PRODUCT. IN FACT, THE MANUFACTURER AND/OR DISTRIBUTOR EXPRESSLY STATES THAT ALL REPAIRS AND PARTS REPLACEMENTS SHOULD BE UNDERTAKEN BY CERTIFIED AND LICENSED TECHNICIANS, AND NOT BY BUYER, THE BUYER ASSUMES ALL RISK AND LIABILITY ARISING OUT OF HIS OR HER REPAIRS TO THE ORIGINAL PRODUCT OR REPLACEMENT PARTS THERETO, OR ARISING OUT OF HIS OR HER INSTALLATION OF REPLACEMENT PARTS THERETO.

# PARTS LIST

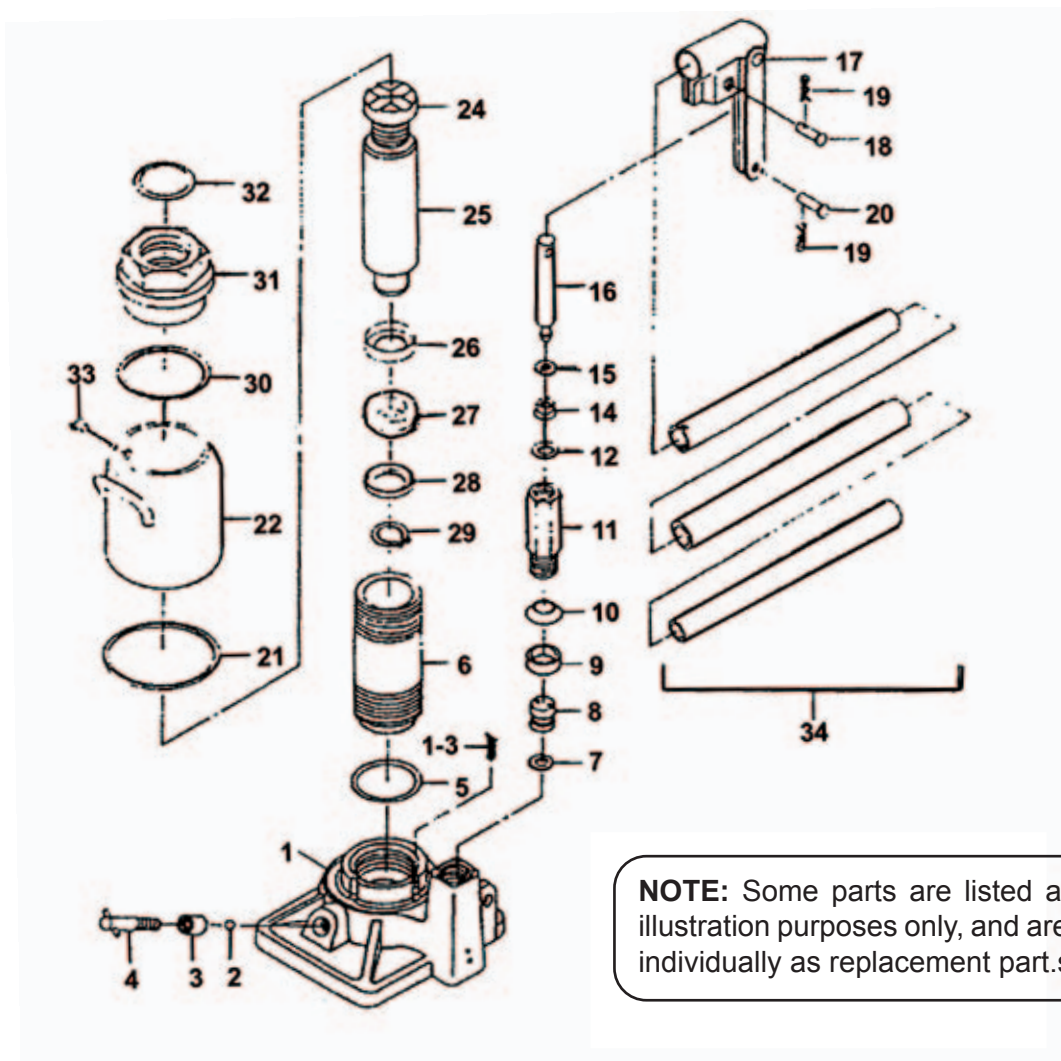

**NOTE:** Some parts are listed and shown for illustration purposes only, and are not available individually as replacement part.s.

No.	Description	No.	Description
1	Base	18	Pin
1-3	Filter	19	Cotter Pin
2	Ball (1/4")	20	Pin
3	Seal	21	Packing
4	Valve Release Screw	22	Housing
5	O-Ring	24	Elevating Screw
6	Cylinder	25	Ram
7	Washer	26	Bushing
8	Check Valve Kit	27	Cup Seal
9	Seal	28	Cap Washer
10	Cap Washer	29	"C" Snap Ring
11	Pump Cylinder	30	Packing
12	O-Ring	31	Top Nut
14	Cup Seal	32	O-Ring
15	Back Up Ring	33	Oil Filler Plug
16	Pump Plunger	34	Handle Assy.
17	Plunger Fulcrum Assy.		