



Assembly & Instruction Manual **ITEM 3116**



750 LB ENGINE STAND

THANK YOU FOR BUYING CUMMINS INDUSTRIAL TOOLS
You can purchase additional items at
www.cumminstools.com

SAVE THIS MANUAL FOR FUTURE REFERENCE



Customer Service Postal Address:
1290 35 Road
Minden, NE 68959
Voice: 1-(308) 832-2070
Fax: 1-(308) 832-2069

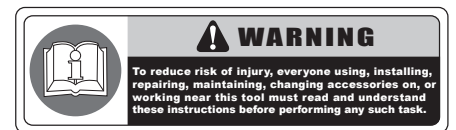

WARNING
To reduce risk of injury, everyone using, installing, repairing, maintaining, changing accessories on, or working near this tool must read and understand these instructions before performing any such task.

Your new 750 LB ENGINE STAND has been engineered and manufactured to Cummins Industrial Tools high standards for dependability, ease of operation, and operator safety. Pay close attention to the Rules for Safe Operation, Warnings, and Cautions. If you use your machine properly and only for what it is intended, you will enjoy years of safe, reliable service.

SAFETY WARNINGS AND PRECAUTIONS

WARNING: When using tool, basic safety precautions should always be followed to reduce the risk of personal injury and damage to equipment. Read all instructions before using the tool!

- **Work area conditions.** Cluttered areas invite injuries.
- **Additional work area conditions.** Do not use machines or power tools in damp or wet locations. Do not expose to rain. Keep work area well lighted.
- **Keep children away.** Children must never be allowed in the work area. Do not let them handle machines, tools or extension cords.
- **Store idle equipment.** When not in use, tools must be stored in a dry location to inhibit rust. Always lock up tools and keep out of reach of children.
- **Use the right tool for the job.** Do not attempt to force a small tool or attachment to do the work of a larger industrial tool. There are certain applications for which this tool was designed. It will do the job better and more safely at the rate for which it was intended. Do not modify this tool and do not use this tool for a purpose for which it was not intended.
- **Dress properly.** Do not wear loose clothing or jewelry as they can be caught in moving parts. Protective, electrically non-conductive clothes and non-skid footwear are recommended when working. Wear restrictive hair covering to contain long hair.
- **Use eye protection.** Always wear ANSI approved impact safety glasses underneath a full face shield during use. Also, wear heavy duty work gloves.
- **Do not overreach.** Keep proper footing and balance at all times. Do not reach over or across running machines.
- **Maintain tools with care.** Keep tools sharp and clean for better and safer performance. Follow instructions for lubricating and changing accessories. The handles must be kept clean, dry, and free from oil and grease at all times.
- **Remove adjusting keys and wrenches.** Check that keys and adjusting wrenches are removed from the tool or machine work surface before starting work.
- **Stay alert.** Watch what you are doing, use common sense. Do not operate any tool when you are tired.
- **Check for damaged parts.** Before using any tool, any part that appears damaged should be carefully checked to determine that it will operate properly and perform its intended function. Any part that is damaged should be replaced.
- **Replacement parts and accessories.** When servicing, use only identical replacement parts. Use of any other parts will void the warranty. Only use accessories intended for use with this tool. Approved accessories are available from Cummins Industrial Tools.
- **Do not operate tools if under the influence of alcohol or drugs.** Read warning labels on prescriptions to determine if your judgment or reflexes are impaired while taking drugs. If there is any doubt, do not operate the tool.

WARNING: The warnings, cautions, and instructions discussed in this instruction manual can not cover all possible conditions and situations that may occur. It must be understood by the operator that common sense and caution are factors which can not be built into this product, but must be supplied by the operator.

ASSEMBLY

- Insert the Middle Beam (#11) into the bottom of the Post (#7). Line up the hole in the middle of the Rear Beam (#9) with the hole on the bottom of the Middle Beam (#11) and use a Bolt (#10) and Washer (#12) and Nut (#13) to secure both the Middle Beam (#11) and the Rear Beam (#9) to the Post (#7).
- Attach the four Holders (#1) to the Plate (#2) with Bolts (#3), Washers (#4), and Nuts (#5).
- Insert the Plate (#2) assembly into the tube on top of the Post (#7) and secure it with the Pin (#6).
- Insert the handle (#8) into the hole of the Plate (#2).
- Attach the Caster (#7) to the Middle Beam (#5) using Washer (#12) and Nut (#13).

NOTE: After assembly, test if the Stand rolls properly. If the hardware is secure, and practice using the Handle (#8) and rotating the Plate (#2). Check it for cracks, bends in the metal, or unusual wear. If any are found, do not use the Stand. Take it to an authorized technician for service or repair.

Operation

Additional Warnings! Do not exceed the maximum capacity of 750 Lbs..

- Always use the Engine Stand on a dry, flat, level surface.
- Never work directly under a suspended engine.
- Do not attempt to move the Stand when under load. The Caster (#17) is not designed to be rolled when the Stand is supporting a heavy weight. If you need to move the engine, you must transfer it to an approved, appropriate moving device such as an engine hoist.
- Make sure the stand is stable. Before using the stand, check it for cracks, bends in the metal, or signs of unusual wear. If any are found, do not use the Stand. Take it to an authorized technician for service or repair.
- Do not attempt to remove an engine from a vehicle using this device. Use an engine hoist (not included). Read all the safety warnings and instructions that came with the engine hoist.
- Be careful not to pinch fingers and hands when adjusting and using the Engine stand.

Using the Engine Stand

- Follow instructions in the vehicle's manual to determine the diameter and length of the bolts (not included) needed to connect your engine block to the four Holders (#1). Make sure you use bolts that are long enough to fit through the Holders (#1) and thread as deeply as possible into the engine block. Place the bolts (not included) through the rear of the Holders (#1) (closest to the Post (#7)) and securely tighten them into the engine block. The head of the bolts must be flush with the rear of the Holders (#1).

ASSEMBLY

- Bring the engine on a hoist in close proximity to the Plate (#2), so you can adjust the Plate (#2) to properly fit and support the engine block. Remove the Pin (#6) and use both hands on the Handle (#8) to turn the Plate (#2) to the desired angle; always stand behind the Engine stand when adjusting the Plate (#2). Replace the Pin (#6) making sure to secure it tightly in place. Secure one of the Nuts (#5) on the rear of the Plate (#2) while loosening a Bolt (#3). Do not remove the Bolt (#3), just loosen it enough to move the Holder (#2) into position. Repeat on the other three Holders (#1) until they are in position to match up with the mounting bolts (not included) coming from the engine block. Tighten the Bolts (#3) securely to the Plate (#2).
- Attach the engine to the Stand after properly aligning the mounting bolts (not included).

NOTE: Use all four Holders (#1) when attaching an engine to the Stand.

- When finished working on the engine, follow the safety warnings and instructions that came with the engine hoist to safely remove the engine from the Stand.

MAINTENANCE

- Keep Engine Stand clean and free of dirt or grease.
- Periodically check that hardware is securely fastened.
- Check that the Caster (#17) and the Wheels (#16) are clean and turn properly.

EXPLODED DIAGRAM & PARTS LIST

Exploded Diagram

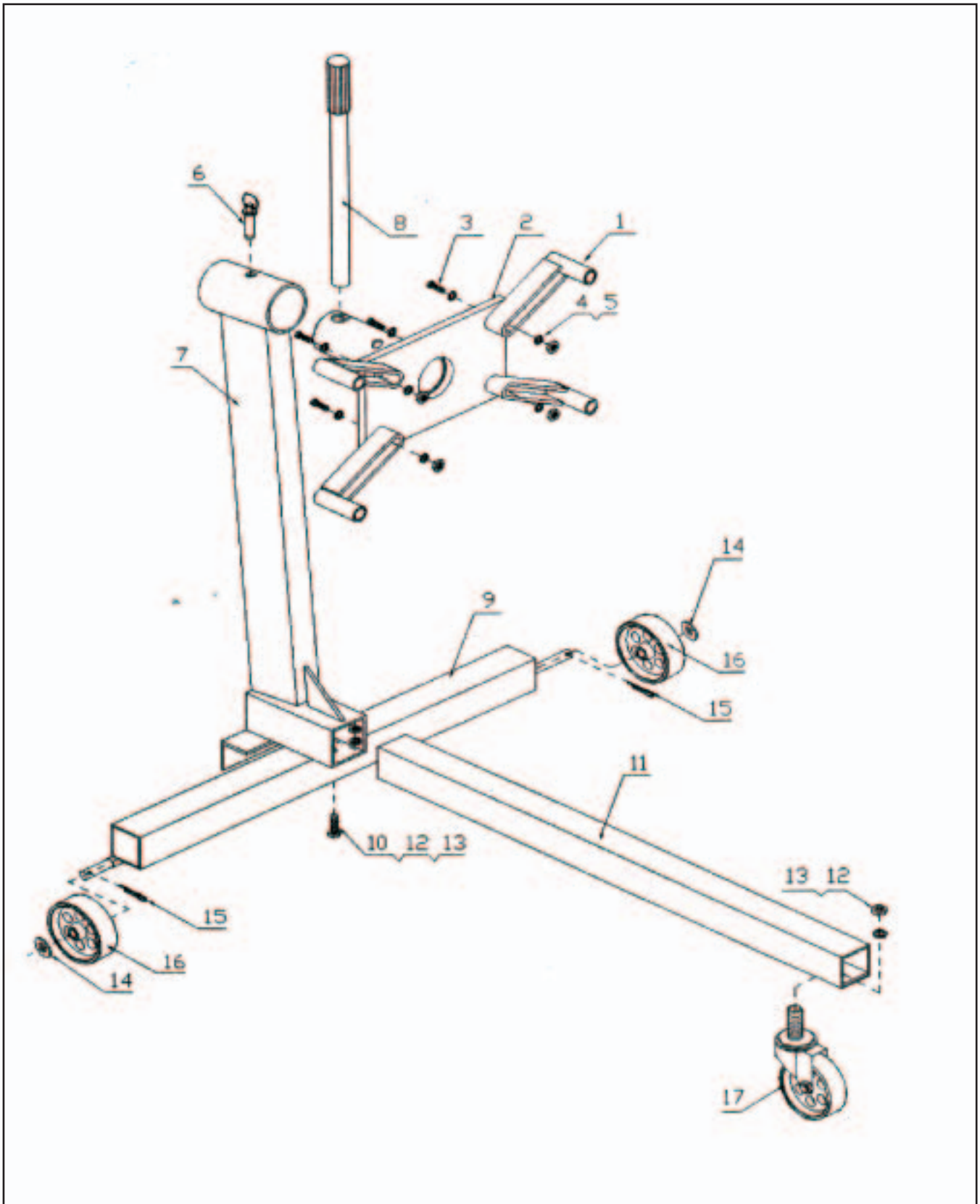

EXPLODED DIAGRAM & PARTS LIST

Parts List

NO	DESCRIPTION	QTY
1	Holder	4
2	Plate	1
3	Bolt M 14x 65	4
4	Washer (14)	8
5	Nut M14	4
6	Pin	1
7	Post	1
8	Handle	1
9	Rear Beam	1
10	Bolt M12 x 80	1
11	Middle Beam	1
12	Spring Washer (12)	2
13	Nut M12	2
14	Washer (12)	2
15	"R" Pin	2
16	Rear Wheel	2
17	3" Caster	1