



Assembly & Instruction Manual **ITEM 3115**
VENDOR: A **SERIES: 1**



5-SPEED DRILL PRESS

THANK YOU FOR BUYING CUMMINS INDUSTRIAL TOOLS
 You can purchase additional items at
www.cumminstools.com

SAVE THIS MANUAL FOR FUTURE REFERENCE



Customer Service Postal Address:
 1290 35 Road
 Minden, NE 68959
 Voice: 1-(308) 832-2070
 Fax: 1-(308) 832-2069



Your new 5-SPEED DRILL PRESS has been engineered and manufactured to Cummins Industrial Tools high standards for dependability, ease of operation, and operator safety. Pay close attention to the Rules for Safe Operation, Warnings, and Cautions. If you use your machine properly and only for what it is intended, you will enjoy years of safe, reliable service.

SAFETY WARNINGS AND PRECAUTIONS

WARNING: When using tool, basic safety precautions should always be followed to reduce the risk of personal injury and damage to equipment. Read all instructions before using the tool!

- **Work area conditions.** Cluttered areas invite injuries.
- **Additional work area conditions.** Do not use machines or power tools in damp or wet locations. Do not expose to rain. Keep work area well lighted.
- **Keep children away.** Children must never be allowed in the work area. Do not let them handle machines, tools or extension cords.
- **Store idle equipment.** When not in use, tools must be stored in a dry location to inhibit rust. Always lock up tools and keep out of reach of children.
- **Use the right tool for the job.** Do not attempt to force a small tool or attachment to do the work of a larger industrial tool. There are certain applications for which this tool was designed. It will do the job better and more safely at the rate for which it was intended. Do not modify this tool and do not use this tool for a purpose for which it was not intended.
- **Dress properly.** Do not wear loose clothing or jewelry as they can be caught in moving parts. Protective, electrically non-conductive clothes and non-skid footwear are recommended when working. Wear restrictive hair covering to contain long hair.
- **Use eye protection.** Always wear ANSI approved impact safety glasses underneath a full face shield during use. Also, wear heavy duty work gloves.
- **Do not overreach.** Keep proper footing and balance at all times. Do not reach over or across running machines.
- **Maintain tools with care.** Keep tools sharp and clean for better and safer performance. Follow instructions for lubricating and changing accessories. The handles must be kept clean, dry, and free from oil and grease at all times.
- **Remove adjusting keys and wrenches.** Check that keys and adjusting wrenches are removed from the tool or machine work surface before starting work.
- **Stay alert.** Watch what you are doing, use common sense. Do not operate any tool when you are tired.
- **Check for damaged parts.** Before using any tool, any part that appears damaged should be carefully checked to determine that it will operate properly and perform its intended function. Any part that is damaged should be replaced.
- **Replacement parts and accessories.** When servicing, use only identical replacement parts. Use of any other parts will void the warranty. Only use accessories intended for use with this tool. Approved accessories are available from Cummins Industrial Tools.
- **Do not operate tools if under the influence of alcohol or drugs.** Read warning labels on prescriptions to determine if your judgment or reflexes are impaired while taking drugs. If there is any doubt, do not operate the tool.

WARNING: The warnings, cautions, and instructions discussed in this instruction manual can not cover all possible conditions and situations that may occur. It must be understood by the operator that common sense and caution are factors which can not be built into this product, but must be supplied by the operator.

ADDITIONAL SAFETY RULES TOOL CARE

WARNING: For your own safety, do not operate your drill press until it is completely assembled and installed according to the instructions. And until you have read and understood the following:

■ STABILITY OF DRILL PRESS

If there is any tendency of the drill press to tilt or move during any use, belt to the bench top or to a piece of exterior plywood large enough to stabilize the drill press. Belt plywood to the underside or the base so it extends to beyond the sides of the base. **DO NOT USE PRESSED WOOD PANELS.** They can break unexpectedly. If the workplace is too large to easily support with one hand, provides an auxiliary support.

■ LOCATION

Use the drill press in a well lit area and on a level surface, clean and smooth enough to reduce the risk of trips and falls. Use it where neither the operator nor the casual observer is forced to stand in line with a potential kickback.

■ PROTECTION: Eyes, Hands, Face, Ears, and Body.

WARNING: To avoid being pulled into the blade. Do not wear: loose fitting gloves, necktie, loose clothing, jewelry. Do not have long hair. Roll long sleeves above elbows

a. If any part of your drill press is missing, malfunctioning, has been damaged or broken, such as the motor switch, or other operating control, a safety device or the power cord; cease operating immediately until the particular part is properly repaired or replaced.

b. Never place your fingers in a position where they could contact the drill bit or other cutting tool if the work piece should unexpectedly shift or your hand should slip.

c. To prevent the work piece from being torn from your hands, spinning on the table, shattering the tool, or being thrown, always support your work so it won't shift or bind on the tool. Always position "backup material" (used beneath the reference) to contact the left side of the column. Whenever possible, position the work piece to contact the left side of the column. If it is too short or the table is tilted, clamp solidly to the table. Use table slots or clamping ledge around the outside edge of the table.

- When using a drill press vise, always fasten to the table.

- Never do work "free hand" (hand holding a work piece rather than supporting in on the table). Expect when polishing.

- Securely lock head and table support to column, and table to table support before operating drill press.

- Never move the head or table support while the tool is working.

- Before starting the operation, jog the motor switch to make sure the drill or other cutting tool does not wobble or cause vibration.

- If a work piece overhangs the table such that it will fall or tip if not held, clamp it to the table or provide auxiliary support.

- Use fixtures for unusual operations to adequately hold, guide and position the work piece.

- Use the SPINDLE SPEED recommended for the specific operation and work piece material, check the panel inside the pulley cover for drilling information: for accessories, refer to the instructions provided with the accessories.

ADDITIONAL SAFETY RULES TOOL CARE

- d. Never climb on the drill press table, it could break or pull the entire drill press down on you.
- e. Turn the motor switch "OFF" and unplug from power source when not in operation.
- f. To avoid injury from thrown work or tool contact. DO NOT perform layout, assembly, or setup work on the table while the cutting tool is rotating.

■ USE ONLY ACCESSORIES DESIGNED FOR THIS DRILL PRESS TO AVOID SERIOUS INJURY FROM THROWN, BROKEN PARTS OR WORK PARTS.

- a. When cutting large diameter holes: clamp the work piece firmly to the table. Otherwise, the cutter may grab and spin at high speed. Use only one-piece, cup-type, hole cutters. Do not use fly cutters or multi-part hole cutters as they can come apart or become unbalanced in use. Keep speed below 1500 rpm.
- b. Drum sanders must NEVER be operated on this drill press at a speed greater than 1000 rpm.
- c. Do not install or use any drill that exceeds 7" in length or extends 6in below the chuck jaws. They can suddenly bend outward or break.
- d. Do not use wire wheels, route bits, shaper cutters, circle (fly) cutters, or rotary planers on this drill press.

■ DIRECTION OF FEED FOR DRUM SANDING.

Feed work piece into a sanding drum, or other approved accessory, against the direction of rotation.

WARNING: A kickback occurs when work piece suddenly binds on the cutting edge of the tool and the work piece is thrown by the cutter in the direction of the cutter's rotation. This can cause serious injury.

■ THIS DRILL PRESS HAS 5 SPEEDS:

760RPM, 1150RPM, 1630RPM, 2180RPM, AND 3070RPM. See inside of guard for specific placement of belt on pulleys.

■ THINK SAFETY. SAFETY IS A COMBINATION OF OPERATOR COMMON SENSE AND ALERTNESS AT ALL TIMES WHEN THE DRILL PRESS IS BEING USED.

WARNING: Do not allow familiarity (gained from frequent use of your drill press) to become commonplace. Always remember that a careless fraction of a second is sufficient to inflict severe injury.

WARNING: The operation of any power tool can result in foreign objects being thrown into the eyes, which can result in severe eye damage. Always wear safety goggles that comply with ANSI Z87.1 before commencing power tool operation.

MOTOR SPECIFICATIONS AND ELECTRICAL REQUIREMENTS

Motor Specifications: This drill press is designed to use 1720 RPM motor only. Do not use any motor that runs faster than 1720 RPM. It is wired for operation on 110-120 volts. 60Hz alternating current.

WARNING: To avoid injury from unexpected start-up, do not use blower or washing machine motors or any motor with an automatic reset overload protector.

Connecting To A Power Source

- This machine must be grounded while in use to protect the operator from electric shock.
- Plug power cord into a 110-120V properly grounded type outlet protected by a 15 amp dual element time delay fuse or circuit breaker.
- Not all outlets are properly grounded. If you are not sure that your outlet, as pictured below, is properly grounded, have it checked by a qualified electrician.

WARNING: To avoid electric shock, do not touch the metal prongs on the plug when installing or removing the plug to or from the outlet.

WARNING: Failure to properly ground this power tool can cause electrocution or serious shock, particularly when used near metal plumbing or other metal objects. If shocked, your reaction could cause your hands to hit the cutting tool.

WARNING: If power cord is worn or cut, or damaged in any way, have it changed immediately to avoid shock or life hazard.

- Your unit is for use on 120 volts. This power tool is equipped with a 3-conductor cord and grounding type plug approved by Underwriters Laboratories and the Canadian Standards Association. The ground conductor has a green jacket and is attached to the tool housing at one end and to the ground prong in the attached plug at the other end.
- The plug requires a mating 3-conductor grounded type outlet as shown.
- If the outlet you are planning to use for this power tool is of the two-prong type. DO NOT REMOVE OR ALTER THE GROUNDING PRONG IN ANY MANNER. Use an adapter as shown and always connect the grounding lug to known ground.
- If the outlet you are planning to use for this power tool is of the two-prong type. DO NOT REMOVE OR ALTER THE GROUNDING PRONG IN ANY MANNER. Use an adapter as shown and always connect the grounding lug to known ground.
- It is recommended that you have a qualified electrician replace the TWO-prong outlet with a properly grounded THREE-prong outlet.

MOTOR SPECIFICATIONS AND ELECTRICAL REQUIREMENTS

- An adapter as shown below available for connecting plugs to 2-prong receptacles.

WARNING: The green grounding plug extending from the adapter must be connected to a permanent ground such as a properly grounded outlet box.

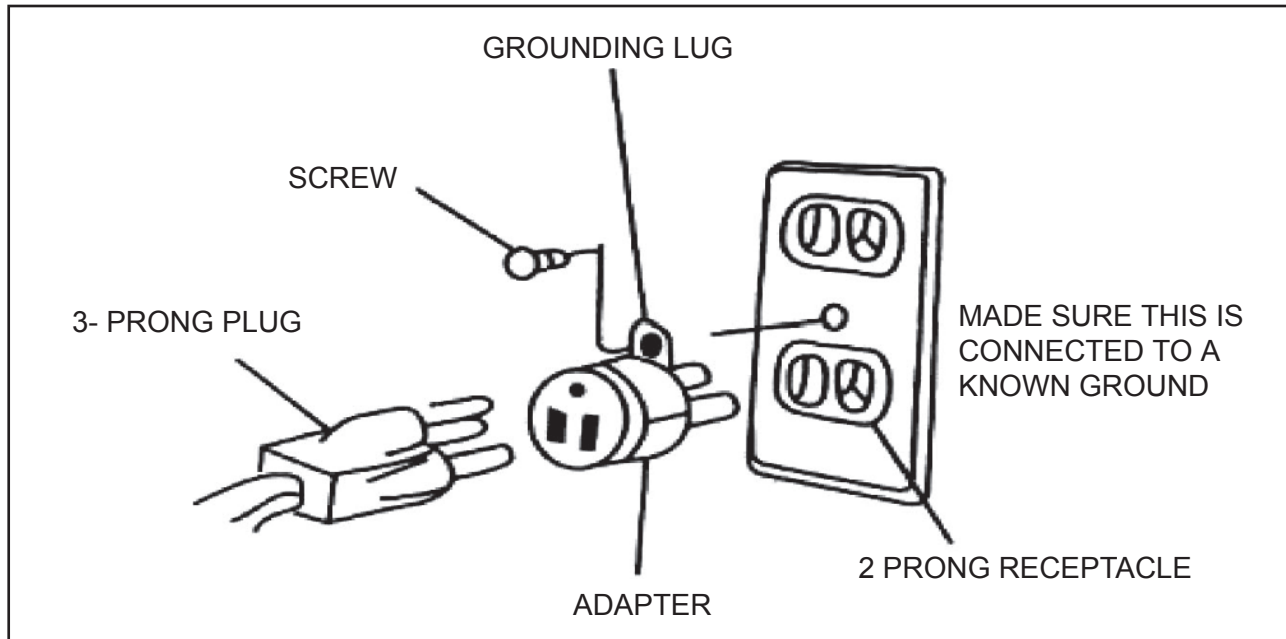

- The use of any extension cord will cause some loss of power. To keep this to a minimum and to prevent over-heating and motor burn-out, use the table below to determine the minimum wire size (A.W.G) for an extension cord. Use only 3-wire extension cords which have 3-prong grounding type plugs and 3-pole receptacles which accept the tools plug.

■ Extension Cord Length	Wire Size A.W.G.
0 - 25 Feet	16
26 - 50 Feet	14
51 - 100 Feet	12

SPEED CHOICES / BELT ADJUSTMENT SPINDLE SPEEDS

- This drill press offers you a choice of 5 spindle speeds from 760 to 3070 RPM. The highest speed is obtained when the belt is positioned on the largest motor pulley step and the smallest spindle pulley step.

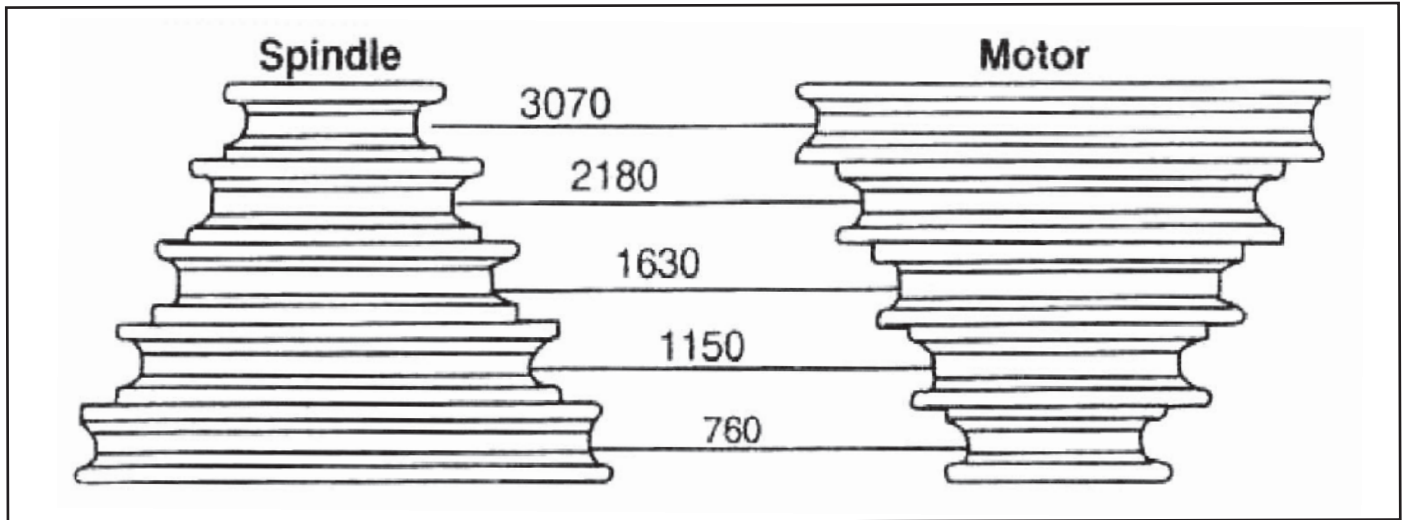

REFERENCE LIST OF DRILL, ROTATION AND VARIOUS MATERIALS TO BE DRILLED

DRILL DIN	materials				
	steel	cast iron	aluminium	plastics	wood
	60Hz	60Hz	60Hz	60Hz	60Hz
3	3070	3070	3070	3070	3070
4	3070	3070	3070	3070	3070
5	2180	3070	3070	3070	3070
6	2180	3070	3070	3070	3070
7	1630	2180	3070	3070	3070
8	1630	2180	3070	3070	3070
9	1150	1630	2180	3070	3070
10	1150	1630	2180	3070	3070
11	760	1150	1630	2180	3070
12	760	1150	1630	2180	3070
13	760	760	1150	1630	2180

ASSEMBLY

■ Assemble the column

Place column assembly on base and align holes in column support with holes in base. Secure the column with the bolts provided.

■ Install table

Slide the table assembly onto the column and lock with clamping lever.

■ Attach head to column

Carefully put the head assembly over column and slide it onto column into position. Align head frame with table and base. Fix set screws into right side of head to lock head into position then tighten.

■ Install the feeding handles

Screw the knobs to the feeding handles.
Screw each feeding handles into hub of pinion shaft.

■ Attach the chuck

Slide table up and secure it approximately 75mm from the tip of the spindle.
Slide short end of arbor into chuck. Place long end inside spindle.
Open chuck jaws completely by turning chuck key anticlockwise to the end.
Put a piece of scrap wood on the table to protect chuck nose.
Pull feeding handle down pressing the chuck against the scrap wood until arbor is secure on the spindle.

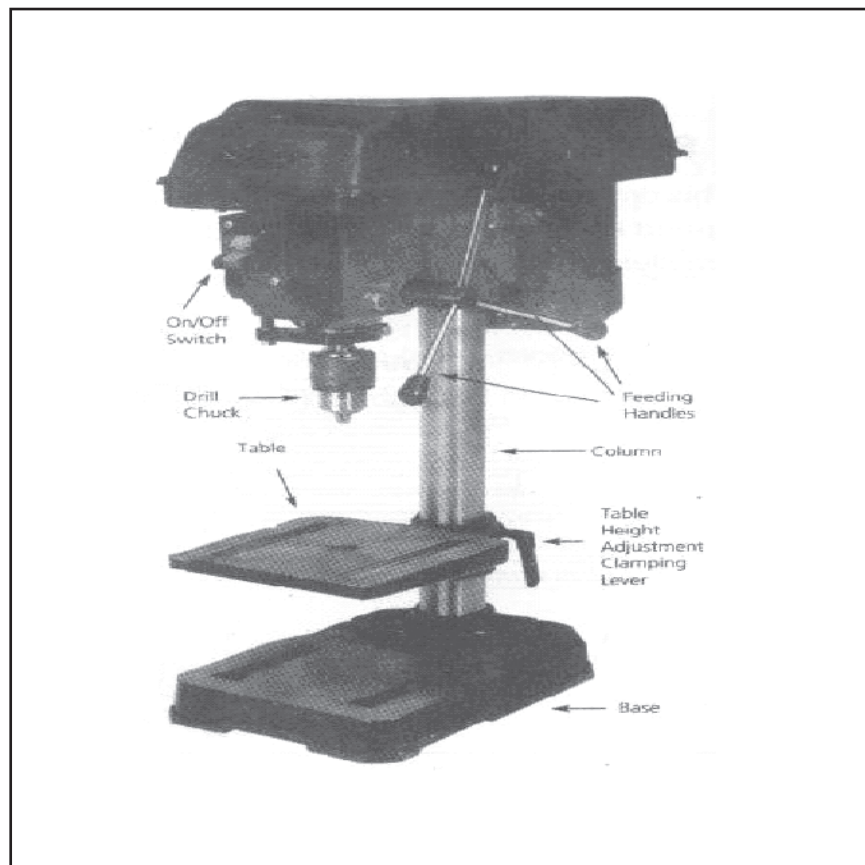

ADJUSTMENT

■ Table adjustment height adjustment: (fig 1)

To adjust up or down, loosen the clamping lever, then adjust the table to desired position and retighten clamping lever securely.



■ Titriling adjustment: (fig 2 & fig 3)

Loosen pivot bolt. Tilt table to desired angle up to 45o and re-tight bolt.



■ Swing 360:

Loosen clamping lever then swing table to appropriate position and retighten.



■ Rotate 360:

Loosen clamping lever, rotate table to desired position and retighten.

■ Depth adjustment feed depth adjustment: (fig 4)

Lower spindle assembly to desired depth and spin down nut. If nut moves due to vibration spin down second nut and lock in position by holding the lower nut and tightening upper nut.

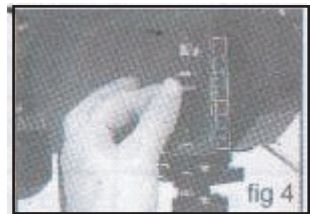

■ Speed adjustment: (fig 5)

Open pulley cover. Loosen shifter bar. Choose speed for drilling operation and move belt to correct position for desired speed. Push motor backward until moderate belt tension is acquired. Tighten shifter bar.



■ Belt tension adjustment: (fig 6)

To gauge proper belt tension, use pressure to push down with the thumb on the belt at midway point between the two pulleys. The belt should push down no more than 13mm.

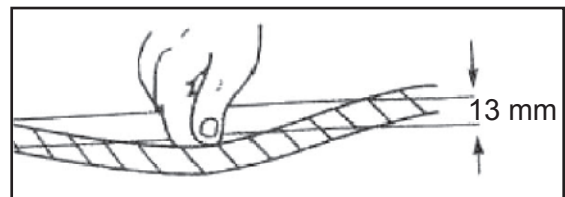

OPERATING INSTRUCTIONS

Installing Drill Bits

- **Open chuck jaws with chuck key (fig 7).**
Insert drill bit chuck jaws approx 25mm. when using a small drill bit do not insert it so far that the jaws touch the arbor of the drill. Make sure that the drill bit is centered in the chuck before tightening the chuck with the key. Tighten all 3 holes.



Operation

- **Drilling:**
use clamps to hold the workpiece when drilling. The workpiece should never be held by hand as the lips of the drill may seize the workpiece at any time, especially when breaking through the stock.
If the workpiece is whirled out of the operators' hand, injury may occur.
For flat work, lay the workpiece on a wooden base and clamp it firmly down against the table to prevent it from turning.
- **Using vice:**
For small workpieces that can not be clamped to the table, use a drill press vice (not included).
The vice must be clamped or bolted to the table.
- **Positioning workpiece:**
Always place a piece of wood on the table. This will prevent splintering or making heavy burs on the underside of the workpiece as the drill breaks through. The wood must contact the left side of the column.
- **Round-out tolerance:**
For drilling operations requiring close tolerances, place drill blank into chuck and check run out with a dial indicator. If the run out is not within desired tolerance, tap the chuck bottom with a rubber mallet until you get the desired tolerance.

EXPLODED DIAGRAM & PARTS LIST

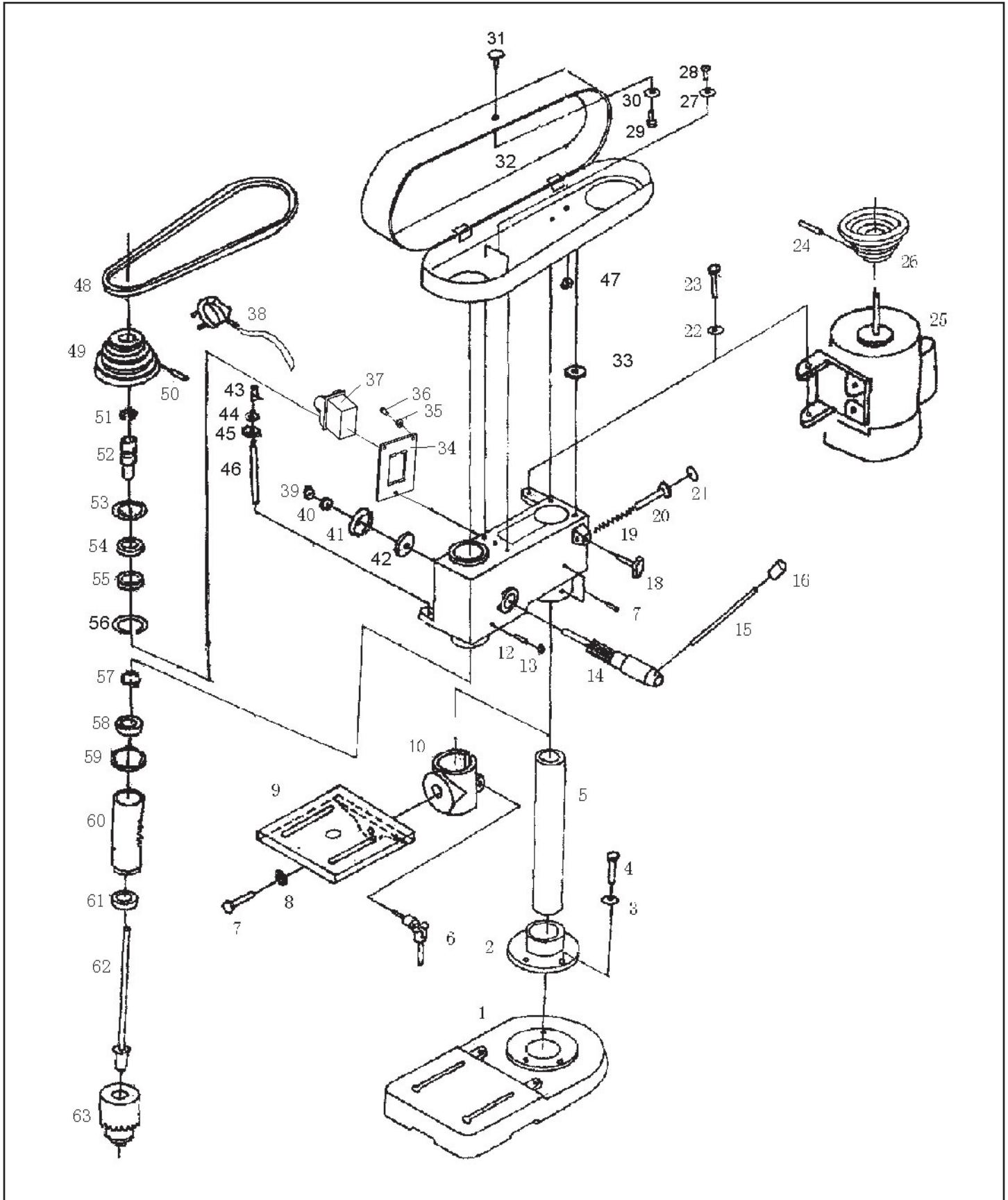

EXPLODED DIAGRAM & PARTS LIST

NO	DESCRIPTION	QTY
1	BASE	1
2	Tube boot	1
3	Washer	3
4	Screw	3
5	Tube	1
6	Support lock handle	1
7	Screw	1
8	spring washer	1
9	Work table	1
10	Table support	1
11	head	1
12	set screw	1
13	nut	1
14	Pinion shaft	1
15	Rod	3
16	Konb	3
17	set screw	2
18	Knob	1
19	Spring	1
20	Motor stop	1
21	foam washer	1
22	flat washer	2
23	Hex screw	2
24	Hex Soc.set screw	1
25	motor	1
26	Motor pulley	1
27	flat washer	4
28	screw	4
29	screw	1
30	flat washer	1
31	Knob	1
32	Guard with labels	1
33	spring washer	4
34	switch cover plate	1
35	flat washer	3
36	screw	3
37	Locking switch	
38	plug and cable	1

NO	DESCRIPTION	QTY
39	nut	1
40	nut	1
41	Spring cap	1
42	tension spring	1
43	point	1
44	nut	1
45	nut	1
46	stop rod	1
47	nut	1
48	belt	1
49	spindle pulley	1
50	hex screw	1
51	retaining ring	1
52	pulley insert	1
53	spacer	1
54	bearing	1
55	bearing	1
56	spacer	1
57	retaining ring	1
58	bearing	1
59	rubber washer	1
60	quill tube	1
61	bearing	1
62	spindle shaft	1
63	chuck	1