



Assembly & Instruction Manual

ITEM 3094

VENDOR: A | SERIES: 1



SWIVEL BASE HYDRAULIC HOIST

THANK YOU FOR BUYING CUMMINS INDUSTRIAL TOOLS
You can purchase additional items at
www.cumminstools.com

SAVE THIS MANUAL FOR FUTURE REFERENCE



Customer Service Postal Address:
1290 35 Road
Minden, NE 68959
Voice: 1-(308) 832-2070
Fax: 1-(308) 832-2069

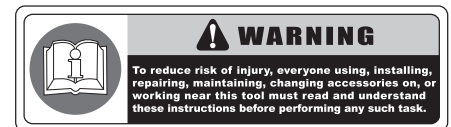

Your new SWIVEL BASE HYDRAULIC HOIST has been engineered and manufactured to Cummins Industrial Tools high standards for dependability, ease of operation, and operator safety. Pay close attention to the Rules for Safe Operation, Warnings, and Cautions. If you use your machine properly and only for what it is intended, you will enjoy years of safe, reliable service.

SAFETY WARNINGS AND PRECAUTIONS

WARNING: When using tool, basic safety precautions should always be followed to reduce the risk of personal injury and damage to equipment. Read all instructions before using the tool!

- **Work area conditions.** Cluttered areas invite injuries.
- **Additional work area conditions.** Do not use machines or power tools in damp or wet locations. Do not expose to rain. Keep work area well lighted.
- **Keep children away.** Children must never be allowed in the work area. Do not let them handle machines, tools or extension cords.
- **Store idle equipment.** When not in use, tools must be stored in a dry location to inhibit rust. Always lock up tools and keep out of reach of children.
- **Use the right tool for the job.** Do not attempt to force a small tool or attachment to do the work of a larger industrial tool. There are certain applications for which this tool was designed. It will do the job better and more safely at the rate for which it was intended. Do not modify this tool and do not use this tool for a purpose for which it was not intended.
- **Dress properly.** Do not wear loose clothing or jewelry as they can be caught in moving parts. Protective, electrically non-conductive clothes and non-skid footwear are recommended when working. Wear restrictive hair covering to contain long hair.
- **Use eye protection.** Always wear ANSI approved impact safety glasses underneath a full face shield during use. Also, wear heavy duty work gloves.
- **Do not overreach.** Keep proper footing and balance at all times. Do not reach over or across running machines.
- **Maintain tools with care.** Keep tools sharp and clean for better and safer performance. Follow instructions for lubricating and changing accessories. The handles must be kept clean, dry, and free from oil and grease at all times.
- **Remove adjusting keys and wrenches.** Check that keys and adjusting wrenches are removed from the tool or machine work surface before starting work.
- **Stay alert.** Watch what you are doing, use common sense. Do not operate any tool when you are tired.
- **Check for damaged parts.** Before using any tool, any part that appears damaged should be carefully checked to determine that it will operate properly and perform its intended function. Any part that is damaged should be replaced.
- **Replacement parts and accessories.** When servicing, use only identical replacement parts. Use of any other parts will void the warranty. Only use accessories intended for use with this tool. Approved accessories are available from Cummins Industrial Tools.
- **Do not operate tools if under the influence of alcohol or drugs.** Read warning labels on prescriptions to determine if your judgment or reflexes are impaired while taking drugs. If there is any doubt, do not operate the tool.

WARNING: The warnings, cautions, and instructions discussed in this instruction manual can not cover all possible conditions and situations that may occur. It must be understood by the operator that common sense and caution are factors which can not be built into this product, but must be supplied by the operator.

SPECIFICATIONS & PARTS LIST

Specifications

■ Max Lifting Capacity	1000 LB	■ Min Lifting Radius	900 MM
■ Max Lifting Height	2400 MM	■ Base Exterior Size	270 x 270 MM
■ Min Lifting Height	580 MM	■ Working Degrees Rotation	360
■ Max Lifting Radius	1320 MM	■ Gross Weight	50 KGS

Parts List

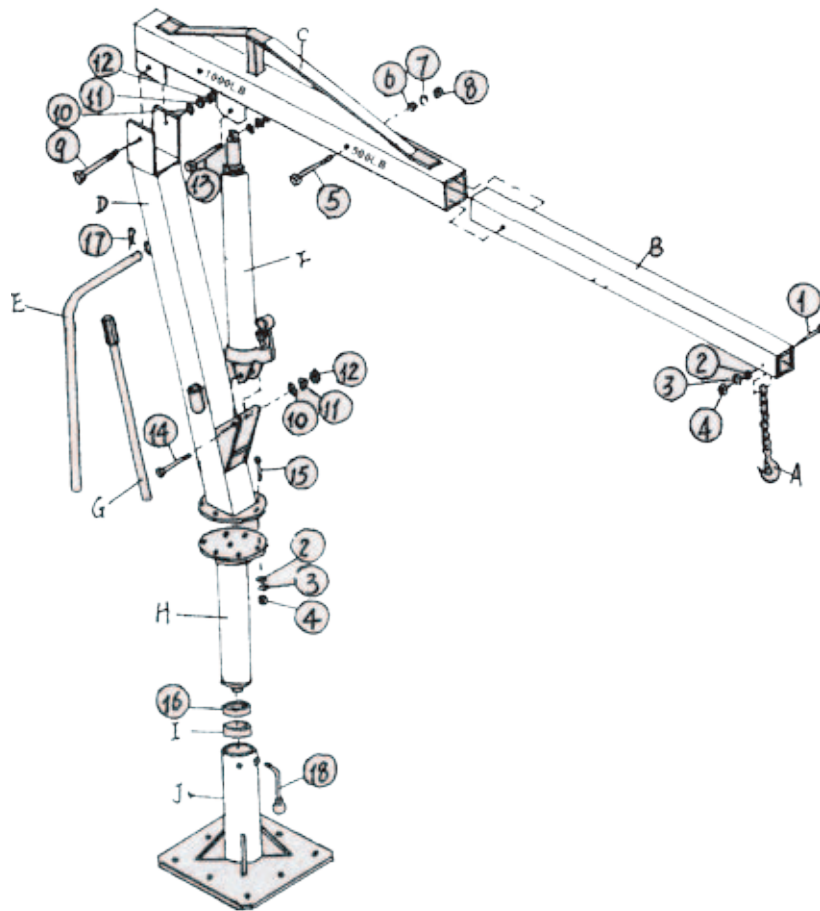

Part No	Description	Qty	Part No	Description	Qty	Part No	Description	Qty
A	Chain&Hook	1	1	Bolt M12x75	1	11	Lock WasherΦ16	3
B	Boom extension	1	2	Flat WasherΦ12	7	12	Nut M 16	3
C	Boom	1	3	Lock WasherΦ12	7	13	Bolt M16x80	1
D	Main post	1	4	Nut M 12	7	14	Bolt M12x95	1
E	Handle	1	5	Bolt M14x90	1	15	Bolt M12x40	6
F	Jack	1	6	Flat WasherΦ14	1	16	Bearing	1
G	Jack Handle	1	7	Lock WasherΦ14	1	17	"R"Pin	1
H	Turntable	1	8	Nut M 14	1	18	Wheel Binding Bolt	1
I	Wheel Hub	1	9	Bolt M16x110	1	19		
J	Base	1	10	Flat WasherΦ16	3	20		