



Assembly & Instruction Manual **ITEM 1124**



AIR IMPACT WRENCH 3/8" DRIVE

THANK YOU FOR BUYING CUMMINS INDUSTRIAL TOOLS
You can purchase additional items at
www.cumminstools.com

SAVE THIS MANUAL FOR FUTURE REFERENCE



Customer Service Postal Address:
1290 35 Road
Minden, NE 68959
Voice: 1-(308) 832-2070
Fax: 1-(308) 832-2069

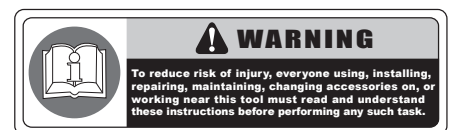

To reduce risk of injury, everyone using, installing, repairing, maintaining, changing accessories on, or working near this tool must read and understand these instructions before performing any such task.

Your new AIR IMPACT WRENCH 3/8" DRIVE has been engineered and manufactured to Cummins Industrial Tools high standards for dependability, ease of operation, and operator safety. Pay close attention to the Rules for Safe Operation, Warnings, and Cautions. If you use your machine properly and only for what it is intended, you will enjoy years of safe, reliable service.

TABLE OF CONTENTS

■ Introduction	1
■ General Safety Rules	2
■ Operating Instructions	3-4
■ Exploded Diagram & Parts List	4-5

INTRODUCTION

- THIS PRODUCT has many features for making the use of this product more pleasant and enjoyable. Safety, performance, and dependability have been given top priority in the design of this product making it easy to maintain and operate.

⚠ WARNING: Do not attempt to use this product until you thoroughly read and completely understand the operator's manual. Pay close attention to the safety rules, including Dangers, Warnings, and Cautions. If you use your product properly and only as intended, you will enjoy years of safe, reliable service.

- ⚠ **Look for this symbol to point out important safety precautions. It means attention!!! Your safety is involved.**



⚠ WARNING: The operation of any tool can result in foreign objects being thrown into your eyes, which can result in severe eye damage. Before beginning operation, always wear safety goggles or safety glasses with side shields and a full face shield when needed. We recommend Wide Vision Safety Mask for use over eyeglasses or standard safety glasses with side shields. Always wear eye protection which is marked to comply with ANSI Z87.1.

GENERAL SAFETY RULES

▲ WARNING: When using tool, basic safety precautions should always be followed to reduce the risk of personal injury and damage to equipment. Read all instructions before using the tool!

- **Work area conditions.** Cluttered areas invite injuries.
- **Additional work area conditions.** Do not use machines or power tools in damp or wet locations. Do not expose to rain. Keep work area well lighted.
- **Keep children away.** Children must never be allowed in the work area. Do not let them handle machines, tools or extension cords.
- **Store idle equipment.** When not in use, tools must be stored in a dry location to inhibit rust. Always lock up tools and keep out of reach of children.
- **Use the right tool for the job.** Do not attempt to force a small tool or attachment to do the work of a larger industrial tool. There are certain applications for which this tool was designed. It will do the job better and more safely at the rate for which it was intended. Do not modify this tool and do not use this tool for a purpose for which it was not intended.
- **Dress properly.** Do not wear loose clothing or jewelry as they can be caught in moving parts. Protective, electrically non-conductive clothes and non-skid footwear are recommended when working. Wear restrictive hair covering to contain long hair.
- **Use eye protection.** Always wear ANSI approved impact safety glasses underneath a full face shield during use. Also, wear heavy duty work gloves.
- **Do not overreach.** Keep proper footing and balance at all times. Do not reach over or across running machines.
- **Maintain tools with care.** Keep tools sharp and clean for better and safer performance. Follow instructions for lubricating and changing accessories. The handles must be kept clean, dry, and free from oil and grease at all times.
- **Remove adjusting keys and wrenches.** Check that keys and adjusting wrenches are removed from the tool or machine work surface before starting work.
- **Stay alert.** Watch what you are doing, use common sense. Do not operate any tool when you are tired.
- **Check for damaged parts.** Before using any tool, any part that appears damaged should be carefully checked to determine that it will operate properly and perform its intended function. Any part that is damaged should be replaced.
- **Replacement parts and accessories.** When servicing, use only identical replacement parts. Use of any other parts will void the warranty. Only use accessories intended for use with this tool. Approved accessories are available from Cummins Industrial Tools.
- **Do not operate tools if under the influence of alcohol or drugs.** Read warning labels on prescriptions to determine if your judgment or reflexes are impaired while taking drugs. If there is any doubt, do not operate the tool.

▲ WARNING: The warnings, cautions, and instructions discussed in this instruction manual can not cover all possible conditions and situations that may occur. It must be understood by the operator that common sense and caution are factors which can not be built into this product, but must be supplied by the operator.

OPERATING INSTRUCTIONS

Specifications

■ AIR INLET	1/4" NPT
■ FREE SPEED	1000 RPM
■ MAX TORQUE	75 FT/LB
■ REG. AIR PRESS	90 PSI

Air Pressure And Volume

- If the tool is not performing the specified jobs, check the following:
- Check if the air compressor has the CFM output to support the air tool.
- Check if the air transmission lines are too small.
- Check if the air hose is too small.
- Check if the hose fitting and couplings are too small.
- Check the compressor regulator.
- Refer to the catalogue specifications for proper air hose size. Use hose that is just long enough to serve the working area. Excessive hose length will cause a drop in pressure.

Common Problems

- Contaminated air such as a dirty air system or water in the system.
- Using the wrong size tool for the job.
- Poor maintenance practices, such as using excessive air pressure or air volume.
- Improper or no lubrications.

Rule Of Thumb

- If it takes more than 8 seconds to tighten or to loosen a bolt or nut with an air impact wrench, the air wrench is too small or the air compressor CFM is not powerful enough for the job. Continuing using the tool will cause damage. Following information will assure proper performance.

Lubrication

- Use light oil containing rust inhibitors, such as SAE # 5W or SAE # 1010w.
- Use grease that is highly water resistant for the front case components on air impact wrenches, grinders, and sanders.

Air System

- Make sure the compressor being used with the air tool supplied adequate output (CFM).
- Equip the air compressor intake with a replaceable air filter that can be easily cleaned.
- Always use moisture traps at the compressor for the main distribution line. Use moisture traps and in line oilers on each downlink that is to be used for air tools.
- Place oiler as close to the air tool as possible for the best lubrication.

OPERATING INSTRUCTIONS

Tool Pressure

- All the air tools should operate at 70-100 PSI (90 PSI preferred), measured while the tool is operating. Pressure in excess of 100 PSI will shorten the life of the tool and cause unnecessary down time.

EXPLODED DIAGRAM & PARTS LIST

Exploded Diagram

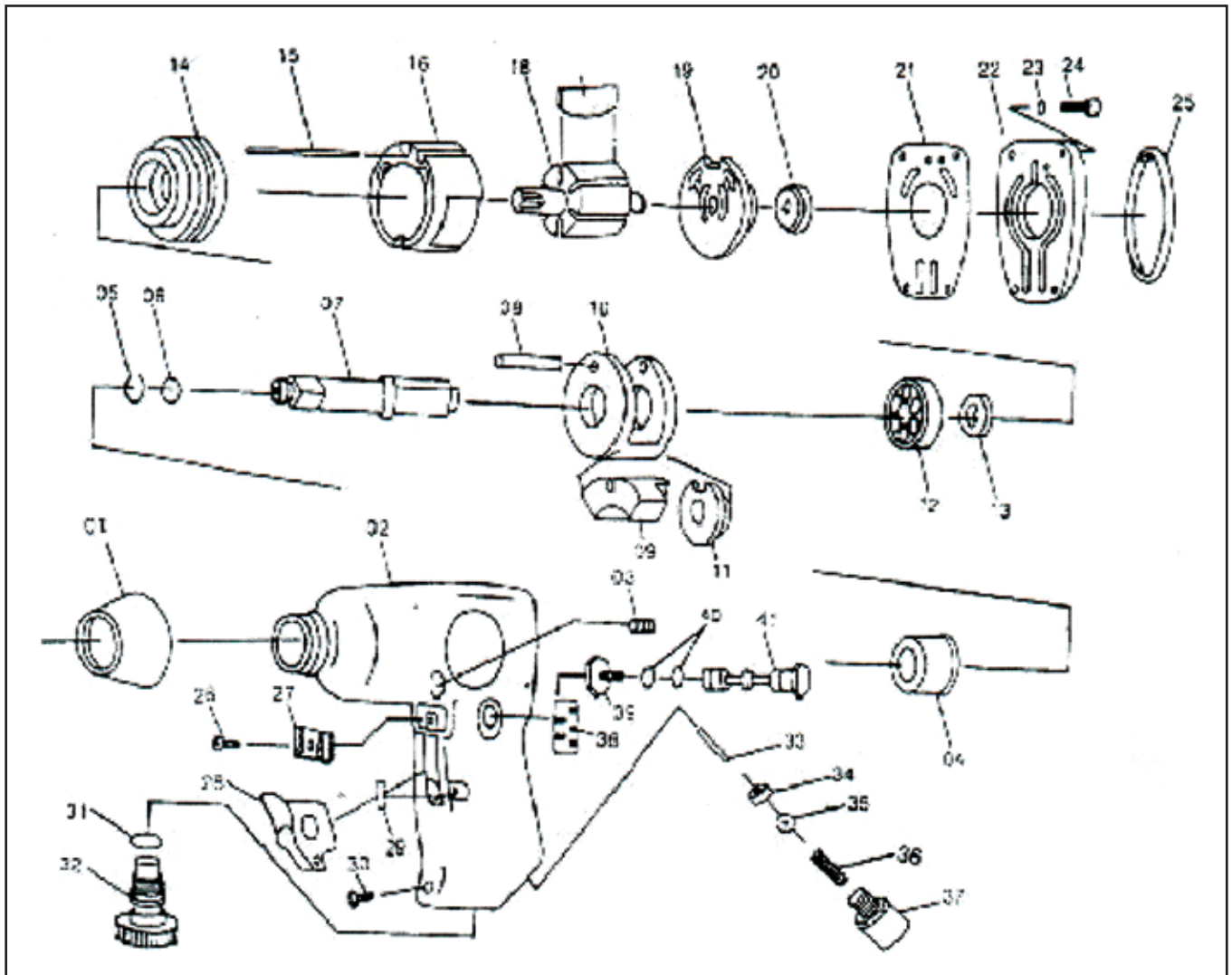

EXPLODED DIAGRAM & PARTS LIST

Parts List

NO	Description	Qty
1	Rubber Nose Guard	1
2	Motor Housing	1
3	Screw	1
4	Spindle Bush	1
5	Socket Retainer	1
6	Socket O-Ring	1
7	Anvil Shank	1
8	Hammer Pin	1
9	Hammer Dog	1
10	Hammer Cage	1
11	Drive Cam	1
12	Ball Bearing	1
13	Oil Seal	1
14	Front End Plate	1
15	Dowel Pin	1
16	Cylinder	1
17	Rotor Blade	6
18	Rotor	1
19	Rear End Plate	1
20	Ball Bearing	1
21	Motor Gasket	1
22	Housing Cap	1
23	Washer	4
24	Cap Screw	4
25	Rubber	1
26	Screw	1
27	Detector	1
28	Trigger	1
29	Pin	1
30	Screw	1
31	O-Ring	1
32	Air Regulator	1
33	Valve Pin	1
34	O-Ring Retainer	1
35	Steel Ball	1
36	Throttle Valve Spring	1
37	Hose Adapter	1
38	Reverse Lever	1
39	Reverse Valve Screw	1
40	O-Ring	1
41	Reverse Valve	1