



NO.1101

Instruction Manual

POWER INVERTER

300 Watt

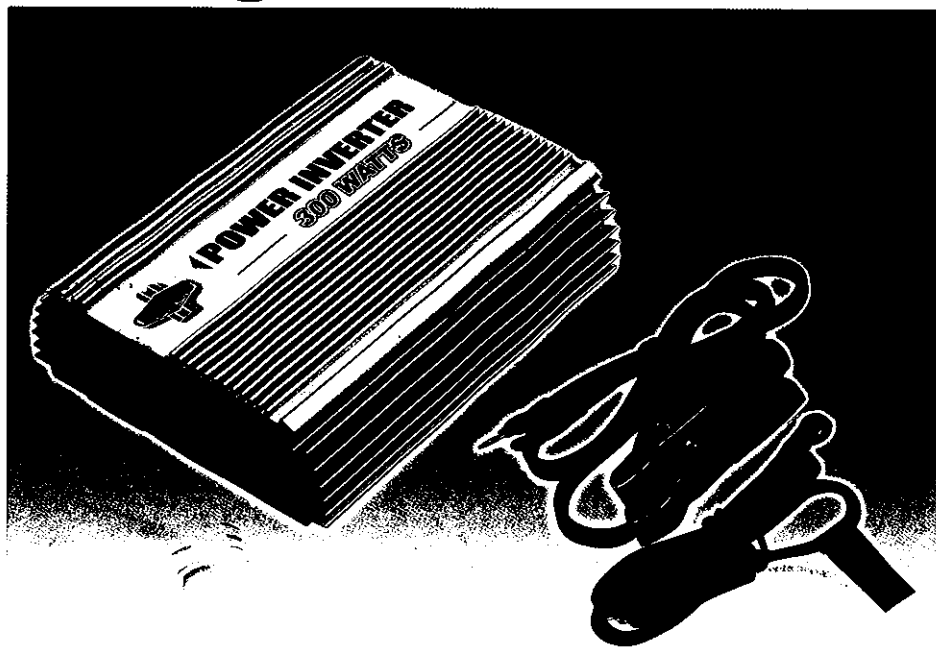

Welcome.

This CUMMINS product has been carefully engineered and manufactured to give you dependable operation. Please read this manual thoroughly before operating your new CUMMINS product, as it contains the information you need to become familiar with its features and obtain the performance that will bring you continued enjoyment for many years. Please keep this manual on file for future reference.

About CUMMINS Inverters.

CUMMINS, an innovator in portable inverter design, has developed a new line of super-efficient power inverters with the highest surge capability in the industry. These extremely advanced, microprocessor controlled units run cooler and more reliable than any in their class. Their superior surge capability allows them to start even the most difficult loads, including color televisions, TV/VCR combinations, microwaves, refrigeration units, even small air conditioners! They also sport the highest efficiency available (up to 90%), which translates into longer running time and extended battery life.

Inverters convert low voltage, direct current (DC) to 110 volt alternating current (AC). Depending on the model and its rated capacity, the inverters draw power either from standard 12 volt automobile and marine batteries or from portable high power 12 volt sources.

Getting Started

When you turn on an appliance or a tool that operates using a motor or tubes, it requires an initial surge of power to start up. This surge of power is referred to as the "starting load" or "peak load."

You will need to determine how much power your tool or appliance requires to start up (starting load) and its continued running power requirements (continuous load).

Power consumption is rated either in wattage (watts), or in amperes (amps), and this information is usually stamped or printed on most appliances and equipment. If this information is not indicated on the appliance or equipment, check the owner's manual or contact the manufacturer to determine if the device you are using is compatible with a modified sine wave source.

Multiply: $AMPS \times 110$ (AC voltage) = WATTS

This formula yields a close approximation of the continuous load of your appliance.

Multiply: $WATTS \times 2$ = Starting Load

This formula yield a close approximation of the starting load of your appliance.

Most often the start up load of the appliance or power tool determines whether your inverter has the capability to power it.

To determine whether the inverter will operate a particular piece of equipment or appliance, run a test. The inverters are designed to automatically shut down in the event of a power overload. This protection feature prevents damage to the unit while testing appliances and equipment with ratings in the 300 watt range.

If an appliance in the 300 watt range will not operate properly when first connected to the inverter, turn the inverter rocker switch ON (I), OFF(O), and ON(I) again in quick succession. If this procedure is not successful, it is likely that the inverter does not have the required capacity to operate the appliance in question.

Important

- The inverter is designed to operate from a 12 volt power source only. Do not attempt to connect the inverter to any other power source, including any AC power source.
- Do not attempt to extend or otherwise modify the 12 volt power cord attached to your inverter.
- 110 volts of current can be lethal. Improper use of your inverter may result in property damage, personal injury or loss of life.

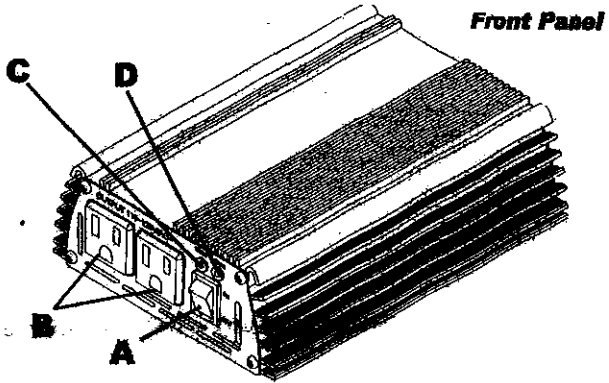

- A . ON/OFF Rocker Switch.**
- B . Dual Standard North American 120V AC Outlets.**
- C . Red LED = Overload.**
- D . Green LED = Power ON.**

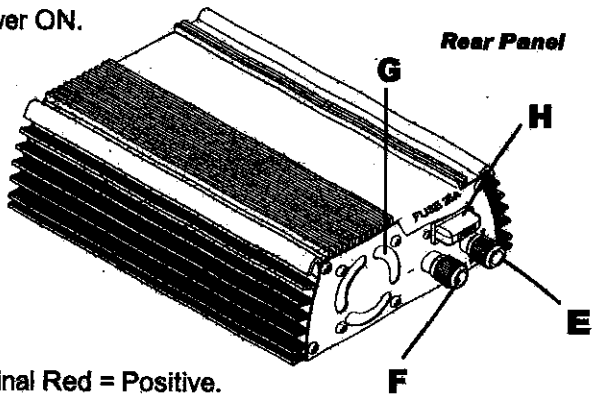

- E . Power Input Terminal Red = Positive.**
- F . Power Input Terminal Black = Negative.**
- G . Cooling Fan.**
- H . Fuse Cover.**

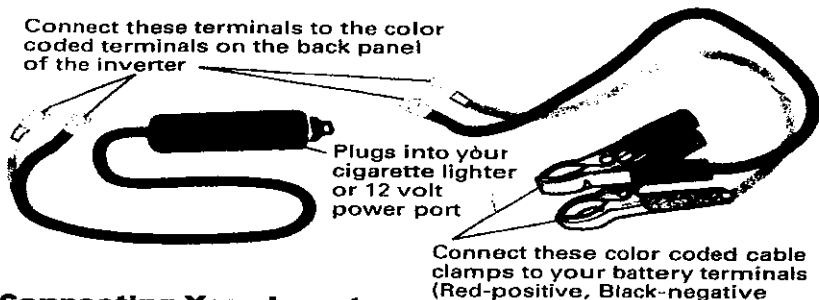

Connecting Your Inverter.

Through the Car Cigarette Lighter or 12 Volt Power Port

1. Make sure the On/OFF rocker switch located on the front panel of the inverter is in the OFF (0) position.
2. Connect the 12 volt power cord the power input terminals at the rear of the inverter making sure to match the color coded cables to the color coded terminals on the inverter (RED = Positive, BLACK = Negative). Do not overtighten these screws.
3. Remove your cigarette lighter and push the 12 volt power plug firmly into the cigarette lighter receptacle in your vehicle.
4. Turn the inverter rocker switch to the ON(I) position. The LED Indicator Light should glow GREEN confirming that there is power running to the inverter.
5. Turn the inverter rocker switch to the OFF (0) position. (The GREEN LED Power Indicator light may "blink" briefly and/ or the internal audible alarm may make a momentary "chirp." This is normal).
6. Check that the appliance to be operated is turned OFF. Plug the appliance into one of the two AC receptacles on the front panel of the inverter.
7. Turn the inverter rocker switch the ON (I) position. Turn the equipment or appliance on.

Directly to the 12 Volt Power Source

- 1 Make sure the ON/OFF rocker switch located on the front panel of the inverter is in the OFF (0) Position.
2. Connect the cables to the power input terminals at the rear of the inverter making sure to match the color coded cables to the color

coded terminals, and tighten the screws to make a secure connection. Do not over tighten these screws.

3. Connect the cable from the Negative (-) terminal (BLACK) on the inverter to the Negative terminal on the 13 volt power source. Double check the connection is secure.
4. Check that the cable you have just installed is properly connected. Make certain that the cable is connected to the negative terminals on both the inverter and the 12 volt power source.
5. Connect the cable from the Positive (+) terminal (RED) on the inverter to the Positive terminal on the power source. Double check that the connection is secure.
6. Follow directions 4-7 in the above section titled "Through the Car Cigarette Lighter or 12 Volt Power Port".

Note:

- The audible alarm many make a momentary "chirp when the inverter is turned OFF(O). This same alarm many also sound when the inverter is being connected to or disconnected from the 12 volt power source.
- Use of an extension cord from the inverter the appliance or equipment being operated will not significantly decrease the power being generated by the inverter. For best operating results, the extension cord should be no more than 50 feet long.
- If the green Led blinks when you first turn the inverter ON, this indicates that there is a short circuit within the power supply. Turn the inverter OFF. Remove the 12 volt plug from the cigarette lighter socket, firmly reinsert the plug, then turn the inverter ON again. Or if you are suing the cables connected to a 12 volt power source, try removing and reconnecting the clamps. If this does not remedy the problem try problem try using a different 12 volt power source.

Blown Automotive Fuses.

Depending on the make and model of you automobile, running the power inverter near full capacity from your cigarette light port many

To avoid blowing an automotive fuse in this situation do not operate the power inverter at peak over 150 watt wattage for extended periods of time from your cigarette lighter of 12 volt power port.

Blown Power Inverter Fuses.

Your power inverter is equipped with a 35 amp spade type fuse. With reasonable care it should not be necessary to replace this fuse. Most blown fuses are the result of reverse polarity or a short circuit within the appliance or equipment being operated. If the fuse happens to blow, disconnect the appliance or equipment immediately, find the source of the problem, repair it, then install a new fuse.

Television and Audio Suggestions

Although these inverters are shielded and filtered to minimize signal interference, some interference with your television picture may be unavoidable, especially with weak signals. However, here are some suggestions that may improve reception.

1. First, make sure that the television antenna produces a clear signal under normal operating conditions (i.e., at home plugged into a standard 110 AC wall outlet). Also, ensure that the antenna cable is properly shielded and of good quality.
2. Change the positions of the inverter, antenna cables and television power cord.
3. Isolate the television, its power cord and antenna cables from the 12 volt power source by running an extension cord from the inverter to the television set.
4. Coil the television power cord and the input cables running from the 12 volt power source to the inverter.
5. Attach a "Ferrite Data Line Filter" to the television power cord. More than one filter may be required. These filters are available at most electronic supply stores.

Note:

- Inexpensive sound systems many emit a "buzzing" sound when operated with the inverter. This is due to inadequate filters in the sound system. There is no solution to this problem short of purchasing a sound system with a higher quality power supply

Source of Power

Most automobile and marine batteries will provide an ample power supply to the inverter for 30 to 60 minutes even when the engine is off. Actual time may vary depending upon the age and condition of the battery, and the power demand being placed on it by the equipment being operated with the inverter.

If you decide to use the inverter while the engine is off, we recommend that you start the engine every hour and let it run for approximately 10 minutes to recharge the battery. We also recommend that the device plugged into the inverter be turned OFF before starting the vehicle engine.

Although it is not necessary to disconnect the inverter when turning over the engine, it may momentarily cease to operate as the battery voltage decreases. When the inverter is not supplying power, it draws very low amperage from the battery and may be left connected to the battery for up to three hours. However, we recommend the inverter always be disconnected when not in use.

Inverter Protection Features.

The RED LED Indicator light will turn on and the inverter will turn itself off automatically when:

1. The power input from the battery drops to 9.5 volts. (When the power input drops to 10.5 volts, an alarm will sound for an extended period).
2. The power input from the battery exceeds 15.5 volts.
3. The continuous draw of the equipment or appliance being operated exceeds 300 watts.
4. The surge draw of the equipment or appliance being operated exceeds 600 watts.
4. The circuit temperature exceeds 165 °F.

Note:

- The inverter is equipped with a cooling fan which is designed to run continuously while the inverter is operation. Automatic shut down caused by high circuit temperatures will occur when the cooling fan is unable to maintain a cool enough temperature for safe operation of the inverter.
- In the event of automatic shut down or continuous audible alarm, turn the inverter rocker switch to the OFF (0) position until the source of the problem has been determined and resolved.

Safety Precautions.

For best results place the power inverter on a reasonably flat surface.

- Keep the inverter dry. Do not expose it to rain or moisture. DO NOT operate the inverter if you .the inverter, the device being operated or any other surfaces the may come in contact with any power source are wet. Water and many other liquids can conduct electricity which may lead to serious injury or death.
- Avoid placing the inverter on or near heating vents, radiators or other sources or heat. Do not leave the inverter in the passenger compartment of your vehicle. Store in a cool dry place. Do not place the inverter in direct sunlight. Ideal air temperature should between 50°and 80° F •
- In order to properly disperse heat generated while the inverter is in operation, keep it well ventilated. While in use, maintain several inches is clearance around the top and sides of the inverter.
- Do not use the inverter near flammable materials. Do not place the inverter in areas such as battery compartments where fumes or gases many accumulate.

How Power Inverters Work.

There are two stages in which a power inverter changes the 12 volt CD (or battery) power into 110v AC (household current).

STAGE 1:

The inverter uses a DC to DC converter to increase the DC input voltage from the power source to 160 volts DC.

STAGE 2:

The inverter then converts the high voltage DC into 110v AC (household current), using advanced MOSEFT transistors in a full bridge configuration.

This design provides all our inverters with the capability to start and run difficult reactive loads, while providing excellent overload capability. The waveform that is generated by this conversion is a "modified sine wave" as shown in the diagram below.

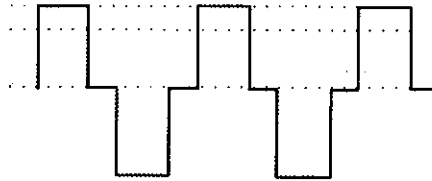

MODIFIED SINE WAVE

The modified sine wave produced by our inverters has a root mean square (RMS) voltage of 110 volts. The majority of AC voltmeters are calibrated for RMS voltage and assume that the measured waveform will be a pure sine wave.



Consequently, these meters will not read the RMS modified sine wave voltage correctly and, when measuring the inverter output, the meters will read about 20 to 30 volts too low. To accurately measure of the output voltage of the inverter, use a true RMS reading voltmeter such as a Fluke 87, Fluke 8060A, Beckman 4410, Triplet! 4200 or any multimeter identified as "True RMS."

result in a blown automotive cigarette lighter fuse. This fuse will need to be replaced with the same size fuse. Please note, a blown automotive fuse will not cause damage to your car wiring.





In Review.

- never attempt to operate the inverter from any power source other than a 12 DC volt battery.
- The inverter is designed to be connected to the power source with the 12 volt power plug. Do not attempt to modify the power cord or plug.
- While connecting the inverter to the power source, make certain the inverter is positioned far away from any potential source of flammable fumes or gases.
- Make certain the power consumption of the appliance or equipment you wish to operate is compatible with the capacity of the inverter. Do not exceed 300 watts.
- When attempting to operate battery chargers, monitor the temperature of the battery charger for approximately 10 minutes. If the battery charger becomes abnormally warm, disconnect it from the inverter immediately.
- Use only 35 amp spade type fuses.
- When operating the inverter with an automobile or marine battery, start the engine every 30 to 60 minutes and let it run for approximately 10 minutes to recharge the battery.
- In the event of a continuous audible alarm or automatic shut off, turn the inverter OFF immediately. Do not restart the inverter until the source of the problem has been identified and corrected.
- To avoid battery drain always disconnect the inverter when not in use.
- Do not expose the inverter to rain or moisture.
- Avoid placing the inverter near sources of heat or in direct sunlight.
- While in use, make sure the inverter is properly ventilated.
- Do not operate the inverter near flammable materials, fumes or gases.

PROBLEM: Low or No Output Voltage

Reason	Solution
 Poor contact with lighter socket or battery clamps,	Unplug and reinsert 12 volt plug or reattach battery clamps.
 Using incorrect type of voltmeter to test output voltage.	Use true RMS reading meter.

PROBLEM:Red Bar Graph

Reason	Solution
 Battery voltage below 9.5 volts.	Recharge or replace battery.
 Equipment being operated draws or too much power,	Use a higher capacity inverter do not use this equipment.
 Inverter is too hot (thermal shut down mode).	Allow inverter to cool. Check for adequate ventilation. Reduce the load on the inverter to rated continuous power output.
 Unit may be defective.	See Warranty and call Customer service.

Troubleshooting

PROBLEM: TV Interference

Reason

Solution



Electrical interference from the inverter,

Add a ferrite data line filter on to the TV power cord. Refer to TV & Audio section of this manual.

PROBLEM: Low Battery Alarm On All The Time

Reason

Solution



Input voltage below 10.5 volts.

Keep input voltage above 10.5 volts to maintain regulation.



Poor or weak battery condition.

Recharge or Replace battery.



Inadequate power being delivered to the inverter or excessive voltage drop.

Check condition of cigarette lighter socket. Clean or replace if necessary. Or check cable clamp connections.

PROBLEM: TV Does Not Work

Reason

Solution



TV does not turn on.

Try turning the inverter ON/OFF/ON.

Contact TV manufacturer for start up surge and/or if the TV is compatible with a modified sine wave.

A large inverter may be required.

SPECIFICATIONS:

Max. Continuous Power	300 Watts
Surge Capability (Peak Power)	600 Watts
No Load Current Draw	<0.5A
Waveform	Modified Sine Wave
Input Voltage Range	11-15 VDC
AC Receptacle	110V AC 3 prong grounded
Fuse35 amp (spade type)
Dimensions	7"3/8Wx5"1/32Lx2"1/16H 187Wx128Lx52Hmm
Weight	2lb, 10z 0.85kg

Power Cord Specification

Parallel wire 2P AWG#12 (Black/Red) With Battery

Clamp x 1 PCS

AWG#14 x 2C(Black) With Cigarette Plug x 1 PCS